



(11) **EP 2 961 441 B1**

(12) **EUROPEAN PATENT SPECIFICATION**

(45) Date of publication and mention of the grant of the patent:  
**25.11.2020 Bulletin 2020/48**

(51) Int Cl.:  
**A61L 2/28** <sup>(2006.01)</sup> **G01N 21/64** <sup>(2006.01)</sup>  
**G01N 21/94** <sup>(2006.01)</sup>

(21) Application number: **14757680.5**

(86) International application number:  
**PCT/US2014/016344**

(22) Date of filing: **14.02.2014**

(87) International publication number:  
**WO 2014/133782 (04.09.2014 Gazette 2014/36)**

(54) **METHOD AND APPARATUS FOR OPTICAL DETECTION OF BIO-CONTAMINANTS**

VERFAHREN UND VORRICHTUNG ZUM OPTISCHEN NACHWEIS VON BIOKONTAMINANTEN

PROCÉDÉ ET APPAREIL DE DÉTECTION OPTIQUE DE CONTAMINANTS BIOLOGIQUES

(84) Designated Contracting States:  
**AL AT BE BG CH CY CZ DE DK EE ES FI FR GB GR HR HU IE IS IT LI LT LU LV MC MK MT NL NO PL PT RO RS SE SI SK SM TR**

- **BARIBEAU, Francois**  
Québec, QC G2G 1E4 (CA)
- **NOISEUX, Isabelle**  
Québec, QC G3A 1Z2 (CA)
- **GOSSELIN, Isabelle**  
Ste-Brigitte-de-Laval  
Québec, QC G0A 3K0 (CA)

(30) Priority: **26.02.2013 US 201313777053**

(43) Date of publication of application:  
**06.01.2016 Bulletin 2016/01**

(74) Representative: **Schweiger, Johannes**  
**Patentanwälte**  
**Becker & Müller**  
**Turmstrasse 22**  
**40878 Ratingen (DE)**

(73) Proprietors:

- **Steris, Inc.**  
Temecula, CA 92590 (US)
- **Institut National d'Optique**  
Québec, Québec G1P 4S4 (CA)

(56) References cited:  
**US-A1- 2003 135 092 US-A1- 2003 135 092**  
**US-A1- 2003 205 682 US-A1- 2007 109 536**  
**US-A1- 2007 109 536 US-A1- 2008 061 236**  
**US-A1- 2012 021 406 US-A1- 2012 315 627**  
**US-A1- 2012 315 627 US-B1- 6 394 111**  
**US-B1- 6 394 111 US-B1- 6 653 146**  
**US-B1- 6 653 146**

(72) Inventors:

- **ROCHETTE, Daniel**  
Painesville, OH 44077 (US)
- **GALLANT, Pascal**  
Québec, QC G2G 2H2 (CA)
- **MERMUT, Ozge**  
Québec, QC G2L 3H1 (CA)

**EP 2 961 441 B1**

Note: Within nine months of the publication of the mention of the grant of the European patent in the European Patent Bulletin, any person may give notice to the European Patent Office of opposition to that patent, in accordance with the Implementing Regulations. Notice of opposition shall not be deemed to have been filed until the opposition fee has been paid. (Art. 99(1) European Patent Convention).

## Description

### Field of the Invention

**[0001]** The present invention relates generally to the cleaning and decontaminating arts, and more particularly to a method and apparatus for optical detection of biological contaminants on articles, such as medical devices, food, agricultural products, forensic equipment and devices, and the like, after undergoing a decontamination process.

### Background of the Invention

**[0002]** Medical washers are conventionally known and are used to clean articles (e.g., medical devices, such as medical instruments and equipment) that have been exposed to bio-contaminants. Such washers typically clean the articles to remove bio-contaminants by directing jets or streams of fluid at the articles from spray heads or nozzles located within the washer. A typical cleaning operation may include a preliminary rinse cycle, a pre-wash cycle, a wash cycle, a post-wash rinse cycle, a thermal rinse cycle and a drying cycle. During the rinse and wash cycles the articles are exposed to one or more chemical cleaning and rinsing solutions.

**[0003]** It is not unusual for a cleaning operation to be followed by a visual inspection conducted by a human to insure that there are no residual bio-contaminants (hereinafter referred to as "soil") on the articles. The soil may include organic residues including, but not limited to, blood, fat, mucous, lipids, carbohydrates, bone, hair, protein, and food product. Some articles have unique shapes, corners or crevices that make removal of the bio-contaminants therefrom difficult. Human visual inspection helps ensure that post-wash articles with soil thereon are not allowed to proceed to further processing (e.g., sterilization) without first removing any remaining bio-contaminants.

**[0004]** As will be appreciated, a human visual inspection is both time-consuming and costly. Moreover, it is difficult to detect minute amounts of soil by human visual inspection, and such visual inspection is subject to human error (for example, person-to-person variations and individual biases). Furthermore, it is observed that human visual inspection is a binary qualitative process, not quantitative.

**[0005]** Some prior art methods for optical detection of soil use a fluorescent dye or agent to detect the presence of soil on an article. In such systems, the fluorescent agent is applied to the article, for example, by exposing the article to a solution that includes the fluorescent agent. The fluorescent agent binds to organic residues (e.g., proteins), and thus affixes to the soil to label the bio-contaminant. Where there is no soil on the article, the fluorescent agent does not become affixed thereto, and thus can be washed off. To provide optical detection of the soil according to prior art methods, the article is

exposed to "black light" (i.e., electromagnetic radiation in the ultraviolet range having wavelengths around 315-400 nm), which is absorbed by the fluorescent agent. Absorbance of this ultraviolet (UV) light causes the fluorescent agent (e.g., a fluorophore such as fluorescein) to emit visible light (i.e., to be fluorescent), thereby identifying the presence of soil to a human inspector. A typical human eye is responsive to light in the wavelength range of 390-750 nm.

**[0006]** This prior art method does not allow personnel to carry out their task of reprocessing of articles in desirable ambient light conditions, and thus makes it difficult for personnel to disassemble, reassemble, and inspect articles for cleanliness. Recommended illuminance levels for such work environments can range from 200 lux to 2000 lux, and more typically range from 1400 lux to 2000 lux.

**[0007]** Document US 2012/0315627 A1 discloses a method of determining effectiveness of a sterilization/disinfection process by providing a biological indicator comprising live organism into which luminescent material is introduced, and exposing the indicator to a sterilization/disinfection process.

**[0008]** Document US 6,653, 126 B1 discloses a bio-burden visualization system for biological material on medical instruments by applying a dye material that can create fluorescence or phosphorescence when applied. The system uses for the determining an illumination with ultraviolet light.

**[0009]** The document US 2003/0205682 A discloses an analysing apparatus for analysing sample material having fluorescing species. The apparatus comprises a mechanism for providing light beams, a photosensitive detector, and a mechanism for receiving and processing signal information.

**[0010]** The present invention provides a method and apparatus for optical detection of soil that operates in preferred ambient lighting conditions.

### Summary of the Invention

**[0011]** According to a first aspect of the present invention, there is provided a soil detection system, as defined in claim 1, for detecting presence of soil on an article.

**[0012]** According to another aspect of the present invention, there is provided a method, as defined in claim 11, for detecting presence of soil on an article.

**[0013]** An advantage of the present invention is the provision of a method and apparatus that uses optical excitation and luminescence (such as fluorescence) to detect the presence of soil on articles that have undergone a washing or rinsing process.

**[0014]** Still another advantage of the present invention is the provision of a method and apparatus that allows optical detection of soil on articles in the presence of ambient light.

**[0015]** These and other advantages will become apparent from the following description of the present in-

vention, taken together with the accompanying drawings and the appended claims.

### **Brief Description of the Drawings**

**[0016]** The present invention may take physical form in certain parts and arrangement of parts, preferred embodiments of which will be described in detail in the specification and illustrated in the accompanying drawings which form a part hereof, and wherein:

FIG. 1 is a schematic view of a soil detection system according to a first embodiment of the present invention;

FIG. 2 is a schematic view of a soil detection system according to a second embodiment of the present invention;

FIG. 3 is a detailed illustration of a soil detection system according to the first embodiment of the present invention;

FIGS. 4A and 4B illustrate internal components of a scanning unit for the soil detection system;

FIG. 5 illustrates a soil detection system according to an alternative embodiment of the present invention;

FIGS. 6A is a graph illustrating the intensity of light emitted by an incandescent light bulb for a range of wavelengths;

FIG. 6B is a graph illustrating the intensity of light emitted by a fluorescent light tube for a range of wavelengths; and

FIG. 6C is a graph illustrating the intensity of light emitted by a computer monitor for a range of wavelengths.

### **Detailed Description of the Invention**

**[0017]** It should be appreciated that the term "medical devices" as used herein, includes, but is not limited to, such articles as surgical, dental, veterinary and mortuary instruments and equipment. The articles may be made of various materials, including, but not limited to, stainless steel.

**[0018]** Referring now to FIGS. 1 and 3, there is shown a soil detection system 30 according to an embodiment of the present invention, generally comprised of a scanning unit 80 and a control unit 40. Scanning unit 80 includes a detector 90, a light source in the form of a laser 100 that produces a laser light 102, a light filter 112, and a dichroic beamsplitter 116 that are located within a housing 81. In the illustrated embodiment, scanning unit 80 is handheld by the user. It should be understood that the light source can alternatively be located external to scanning unit 80 and an optical fiber used to transmit light from the external light source to scanning unit 80.

**[0019]** In the illustrated embodiment, detector 90 takes the form of a conventional digital video/still camera that includes a CMOS (complementary metal-oxide semicon-

ductor) or CCD (charge-coupled device) image sensor 92 and a lens 94. A CCD image sensor 92 represents pixels by p-doped MOSFET capacitors. These capacitors are biased above the threshold for inversion when image acquisition begins, allowing the conversion of incoming photons into electron charges at the semiconductor-oxide interface. Image sensor 92 is then used to read out these charges. Detector 90 is adapted to detect electromagnetic radiation emanating from said articles and generate corresponding information (i.e., light data) that is delivered to control unit 40. It should be understood that detector 90 may take the form of any suitable device able to detect electromagnetic radiation and produce an image, including, but not limited to, a CMOS sensor, a CCD, a photodiode, and a photodiode array. In the illustrated embodiment, image sensor 92 takes the form of a color image sensor, such as CCD or CMOS with RGB (Red-Green-Blue) pixel matrix, or a three-dimensional image sensor where color RGB planes are stacked on the same chip, such as 3-CCD or 3-CMOS. These image sensors provide access to each color channel individually for image processing.

**[0020]** In the illustrated embodiment, laser 100 is preferably a laser diode that predominantly emits light ("laser light") at a wavelength of 488 nm (blue). As will be explained in further detail below, the laser light excites a fluorescent agent (e.g., a fluorophore such as fluorescein). Two- and three-dimensional images may be obtained since fluorescence takes place in all directions (i.e., the fluorescence signal is usually isotropic). Furthermore, the signal-to-noise ratio of the fluorescence signal is very high, providing a good sensitivity. In the illustrated embodiment, the fluorescent agent is fluorescein, which has a maximum excitation at light having a wavelength of about 490 nm. Once excited, the fluorescein emits light at a wavelength of about 513 nm. Since the emitted, fluorescent light is of a different frequency than the excitation light, the excitation light can be filtered out. The intensity of light emitted from a region having the fluorescent agent is correlated to the intensity of excitation energy and to the concentration of the fluorescent agent.

**[0021]** It should be understood that the light source of the present invention for producing light emitted by scanning unit 80 may take a number of different forms, including, but not limited to, any kind of device being able to emit a monochromatic or broadband electromagnetic field. Examples of such devices include lasers, solid-state lasers, laser diodes, argon ion lasers, micro wire lasers, diode solid-state lasers, vertical cavity surface emitting lasers, light emitting diodes (LED), organic light emitting diode (OLED), polymer light emitting diode (PLED), quantum dot based light sources, white light sources, halogen lamps, phosphor-coated LEDs, thin-film electroluminescent devices, phosphorescence OLEDs, inorganic/organic LEDs, LEDs using quantum dot technologies, LED arrays, flood light systems using LEDs, white LEDs, filament lamps, arc lamps, gas lamps and fluorescent tubes.

**[0022]** Dichroic beamsplitter 116 is used to both reflect and filter light, depending upon the direction the light is traveling toward dichroic beamsplitter 116. In one direction, dichroic beamsplitter 116 reflects blue light emitted by laser 100 to direct laser light 102 through an opening 81a in housing 81. In a second direction, dichroic beamsplitter 116 cuts blue light and allows green and red light to pass therethrough for reception by detector 90. Accordingly, dichroic beamsplitter 116 prevents any excitation light (in this case, blue light emitted by laser 100) from being received by detector 90. It should be appreciated that a combination of a reflective member (e.g., a dichroic mirror) and one or more light filters may be substituted for dichroic beamsplitter 116. In the embodiment illustrated in FIG. 1, filter 112 is preferably a dual band filter that permits only red and green light to pass there-through and be received by detector 90.

**[0023]** As shown in FIG. 3, housing 81 includes a handle grip 84. A trigger 86 is provided to activate scanning unit 80, as will be explained below. A cable 82 electrically connects scanning unit 80 with control unit 40.

**[0024]** In the illustrated embodiment of the present invention, control unit 40 includes a display unit 42 (e.g., an LCD or LED display unit), a user input interface 44 (e.g., buttons, knobs, keypad, and the like) for control and programming of control unit 40, and an audio output 48 (e.g., a speaker) for emitting audible sounds. A power cord 50 connects control unit 40 to a power source (e.g., a conventional AC electrical outlet). The power source may also supply power to scanning unit 80 through control unit 40. Control unit 40 includes a processing unit and data storage to perform image processing on the light data collected by detector 90 and provides an audible and/or visual soil detection feedback using audio output 48 and display unit 42. A detailed description of the operation of control unit 40 and scanning unit 80 is provided below.

**[0025]** The present invention will now be further described with reference to detection of soil on articles that have been exposed to a solution containing a fluorescent agent (e.g., fluorescein, which is biocompatible). For example, a medical washer (washing apparatus) may be provided to remove bio-contaminants from articles placed in a washing chamber by directing jets or streams of fluid at the articles from spray heads or nozzles located within the washer chamber. The washer may be configured to expose the articles to a solution containing the fluorescent agent during the washer's standard wash cycle and/or rinse cycle. The fluorescent agent (non-specifically) binds to organic residues (e.g., proteins), and thus affixes to soil on the articles to label the bio-contaminant. Where there is no soil on the article, the fluorescent agent does not become affixed thereto (i.e., is unbound), and therefore can be easily rinsed off of the article. In a preferred embodiment, no extra wash time is required for labeling the bio-contaminant and no extra rinse time is required to remove all of the unbound fluorescent agent. Accordingly, no changes are required of existing

medical washers with respect to standard wash and rinse cycles (i.e., no additional "marking" cycle, or pre-wash cycle, etc. is required). In one embodiment of the present invention, fluorescein is used as the fluorescent agent at a concentration in the range of about 0.001 mM to 90 mM (for example, around 0.3 mM) with an exposure time in the range of 30 seconds to 5 minutes to label the bio-contaminant.

**[0026]** It is contemplated that the washer may include a source of a fluorescent agent that is introduced into a water inlet line to the washing chamber during a desired stage of the washing and/or rinsing cycles. A valve controls the flow of the fluorescent agent into the water inlet line. Preferably, the solution containing the fluorescent agent is introduced into the washing chamber during a later stage of the washing cycle. Therefore, during a subsequent rinsing cycle, the fluorescent agent can be removed from unsoiled portions of the articles. The solution containing the fluorescent agent may be combined with a washing solution that includes a decontaminating agent or cleaning detergent. The decontaminating agent or cleaning detergent may initially be in a liquid or dry powder form. The fluorescent agent may be directly added to the decontamination or cleaning detergent before the detergent is added to the washing chamber.

**[0027]** It should be appreciated that while an illustrated embodiment of the present invention is described herein with reference to "fluorescein" as the fluorescent agent, it is contemplated that alternative fluorescent agents may be substituted for fluorescein. A selected fluorescent agent preferably has the following properties: approval by government regulatory authorities (e.g., FDA); biocompatible in such a way that remaining traces of the fluorescent agent on an article can be safely introduced into the human body without incurring health problems; binds rapidly to proteins (e.g., within a few seconds); has the ability to withstand exposure to harsh washing environment conditions (i.e., harsh chemicals and temperatures exceeding 80 °C); water soluble; and high quantum yield. Alternative fluorophores include, but are not limited to, rose bengal, acid red, phthalocyanine, and luminol.

**[0028]** While the present invention has been described in connection with the use of a fluorescent agent, it is also contemplated that the present invention may be adapted for use with alternative chemical agents that provide luminescence, including but not limited to, chemical agents which provide phosphorescence, chemiluminescence, or bioluminescence.

**[0029]** Referring now to FIGS. 1 and 3, one or more articles 10 (e.g., a tool or instrument) which have been exposed to a solution containing fluorescein are placed in a tray 5. The articles are preferably arranged in a single layer to provide exposure to the light emitted by the light source, as will be described below.

**[0030]** An operator of soil detection system 30 grabs handle grip 84 to manually move scanning unit 80 over the surfaces of an article 10 while activating laser 100 using trigger switch 86. Activation of trigger switch 86

causes laser 100 to produce a laser light 102 at a wavelength of 488 nm (blue light). The laser light 102 is reflected by dichroic beamsplitter 116 and travels through opening 81a of housing 81 and is directed toward article 10.

**[0031]** Article 10 is exposed to both ambient light and laser light 102 as scanning unit 80 is moved over the surfaces of article 10. FIGS. 6A-6C show the intensity of ambient light produced at various wavelengths for ambient lighting sources, such as an incandescent bulb, a fluorescent tube light, and a computer monitor screen, respectively. As discussed above, when the fluorescein that binds to soil is exposed to the laser light 102 at a wavelength of about 490 nm, the fluorescein emits light (i.e., fluoresces) at a wavelength of about 513 nm.

**[0032]** Reflected ambient light ( $L_R$ ) and fluorescent light ( $L_F$ ) emitted by the excited fluorescein pass through dichroic beamsplitter 116 and filter 112 before traveling through lens 94 of detector 90. Filter 112 allows only red and green light to pass therethrough to detector 90. The light transmitted through lens 94 is received by image sensor 92.

**[0033]** As scanning unit 80 is moved across article 10, the user squeezes trigger 86, thereby activating laser 100 to produce laser light 102 that is emitted from housing 81 through opening 81a. Laser light 102 is incident on article 10 as scanning unit is moved across article 10. Ambient light is also incident upon article 10, thereby producing ambient light reflections that will include both red and green light. When the fluorescent agent (i.e., fluorescein) present in the soil is excited by laser light 102 the soil fluoresces thereby emitting light at a wavelength of about 513 nm (green light). Both the reflected ambient light ( $L_R$ ) and the fluorescent light ( $L_F$ ) of the soil pass through filter 112 which filters out all but red and green light. Therefore, image sensor 92 only receives red and green light.

**[0034]** Referring now to FIG. 1, there is shown a sample input spectrum 120. As scanning unit 80 is moved across article 10, image sensor 92 acquires and transmits to control unit 40 detected light data indicative of input spectrum 120 that includes a green light waveform 122 and a red light waveform 124. Green light waveform 122 is indicative of the intensity of green light detected by image sensor 92 and red light waveform 124 is indicative of the intensity of red light detected by image sensor 92.

**[0035]** Control unit 40 is programmed to spectrally discriminate between soil fluorescence (indicating the presence of soil) and specular ambient light reflections, based upon the measure of saturation of green light intensities relative to red light intensities (ratio). In the illustrated embodiment, the range of this measure of saturation is enclosed between zero and one. Accordingly, the system is robust to the variations of ambient light of the surrounding environment and changes of acquisition parameters. A value of saturation close to zero is indicative of the presence of specular ambient light reflections, whereas

a large value close to one is indicative of the presence of soil.

**[0036]** Control unit 40 may be programmed to display the detected light data to a user on display unit 42. Control unit 40 may also be programmed to provide the user with a visual and/or audible indicator (e.g., warning/alarm/feedback) via display unit 42 and audio output 48 in the event that the ratio of green light intensity-to-red light intensity indicates the presence of soil. It is further contemplated that control unit 40 may present an image of article 10 and use display unit 42 to display the location of the detected soil (i.e., contaminated region) on article 10. The image of article 10 may be acquired during optical scanning of article 10 or from a prestored image library comprised of images of a plurality of commonly used articles 10.

**[0037]** Referring now to FIG. 2, there is shown a soil detection system 30A according to an alternative embodiment of the present invention. Soil detection system 30A is similar to soil detection system 30 in several regards, and thus like components have been given the same reference numbers. Soil detection system 30A includes scanning unit 80A having laser 100, detector 90, a power modulator 34, dichroic beamsplitter 116, and a light filter 112A that allows only green light to pass therethrough. Power modulator 34 produces a pulsed waveform that provides an ON/OFF signal to activate/deactivate laser 100. When the pulse is an ON signal, laser 100 is activated to produce laser light 102. The pulsed waveform causes laser 100 to be continuously pulsed ON and OFF at a laser modulation frequency. As scanning unit 80A is moved across article 10, the user squeezes trigger 86, thereby activating power modulator 34 to produce the pulsed waveform that provides the ON/OFF signal to laser 100. When the pulse is an ON signal, laser light 102 is emitted from housing 81 through opening 81a. It should be appreciated that power modulator 34 may alternatively take the form of a square wave modulation circuit to modulate the output of laser 100 (amplitude modulation).

**[0038]** Laser light 102 is incident on article 10 as scanning unit is moved across article 10. Ambient light is also incident upon article 10, thereby producing ambient light reflections that will include green light. When the fluorescent agent (e.g., fluorescein) present in the soil is excited by laser light 102 the soil fluoresces thereby emitting light at a wavelength of about 513 nm (green light). Both the reflected ambient light ( $L_R$ ) and the fluorescent light ( $L_F$ ) of the soil passes through filter 112 which filters out all but green light. Therefore, image sensor 92 only receives green light. In this embodiment, image sensor may take the form of a color or gray-scale type sensor.

**[0039]** The modulation frequency for laser 100 is set to be lower than the emission frequencies of ambient lighting sources. Detector 90 operates in a continuous (video) mode at a frame rate that is higher than the modulation frequency. Green blinking features on display unit 42 of control unit 40 at the modulation frequency are indicative of soil. Non-blinking features or blinking at fre-

quencies other than the modulation frequency are identified as ambient light reflections. In one embodiment of the present invention the modulation frequency is around 10 Hz. The frequency of ambient lighting sources are  $f = 20\text{-}60\text{kHz}$  (electronic ballast fluorescent tube),  $f = 120\text{ Hz}$  (incandescent light bulb and magnetic ballast fluorescent tube), and  $f = 240\text{ Hz}$  (computer monitor).

**[0040]** As scanning unit 80A is moved across article 10, power modulator 34 produces the pulsed waveform that causes detector 90 and laser 100 to be continuously pulsed ON and OFF. As indicated above, filter 112A only allows green light to pass therethrough to detector 90. Image sensor 92 acquires and transmits to control unit 40 detected light data indicative of the intensity of green light detected by image sensor 92.

**[0041]** FIG. 5 illustrates a soil detection system 30B according to an alternative embodiment of the present invention. Soil detection system 30B includes a control unit 40A having an inspection chamber 60 for inspecting articles 10 placed on a tray 5. A plurality of scanning units 80B are located within chamber 60 for exposing the plurality of surfaces of an article 10 to laser light 102. Scanning units 80B are similar in most respects to scanning units 80 and 80A except that they are automatically activated by control unit 40A. The embodiment shown in FIG. 5 eliminates the need for the user to manually activate a handheld scanning unit 80, 80A and manually expose all of the surfaces of an article 10 to laser light 102.

**[0042]** It is contemplated that tray 5 may also be connected with an apparatus (now shown) for rotating, shaking, or otherwise moving tray 5 within chamber 60. It is further contemplated that scanning units 80B may be mounted to moveable arms (not shown) to provide a range of motion for each scanning unit 80B. Control unit 40 is programmed to control movement of tray 5 and scanning units 80B.

**[0043]** The foregoing description discloses specific embodiments of the present invention. It is contemplated that the scanning unit of the present invention could communicate with the control unit via wireless communications. It is also contemplated that the method and apparatus of the present invention may also be used in combination with automated and human visual inspections using "white light" imaging. In addition, it is further contemplated that the present invention may be adapted to include a fiber optic accessory for point inspection of catalyzed instruments. However the scope of the present invention is defined in the claims.

## Claims

1. A soil detection system (30A) for detecting presence of soil on an article (10), the soil detection system (30A) comprising:  
a scanning unit (80A) for scanning the article with a luminescent agent bound to soil present on the article, the luminescent agent emitting luminescent light

at a wavelength of visible light, wherein said luminescent agent is a fluorescent agent and emits a fluorescent light as said luminescent light, wherein the scanning unit is moveable over a surface of the article, said scanning unit including:

a laser light source (100) for producing a light that is continuously pulsed ON and OFF at a modulation frequency to be incident on the article (10), wherein the modulation frequency of the light produced by the light source is lower than an emission frequency of an ambient light source incident on the article,  
a light filter (112A) that allows passage of only green light,  
a detector (90) for detecting electromagnetic radiation emanating from said article (10) that is filtered by the light filter (112A) and generating light data corresponding thereto, said detector (90) operating at a frame rate higher than the modulation frequency of the light produced by the light source (100) and  
a control unit (40) for receiving the light data generated by the detector (90) to determine the presence of soil on the article (10), said control unit including a display unit for displaying (i) green blinking features that blink on the display unit at the modulation frequency indicative of the soil and (ii) non-blinking features or blinking features that blink on the display unit at frequencies other than the modulation frequency indicative of the ambient light reflected by the article.

2. A soil detection system (30A) according to claim 1, wherein said scanning unit (80A) includes a dichroic beamsplitter that reflects the light produced by the light source and passes the reflected ambient light and the emitted fluorescent light.
3. A soil detection system (30A) according to claim 1, wherein said fluorescent agent is fluorescein.
4. A soil detection system (30A) according to claim 3, wherein said fluorescein concentration is in the range of about 0.001 mM to 90 mM.
5. A soil detection system (30A) according to claim 1, wherein said fluorescent agent binds to proteins.
6. A soil detection system (30A) according to claim 1, wherein said fluorescent agent is bio-compatible.
7. A soil detection system (30A) according to claim 1, wherein said laser is a laser diode that predominantly emits light at wavelengths of 488 nm.
8. A soil detection system (30A) according to claim 1, wherein said detector (90) includes a CMOS image

sensor or a CCD image sensor.

9. A soil detection system (30A) according to claim 1, wherein said control unit (40) includes an inspection chamber having at least one said scanning unit (80A) therein and/or an audio output (48) to provide an audible feedback if soil is detected.

10. A soil detection system (30A) according to claim 1, wherein said article is a stainless steel surgical instrument.

11. A method for detecting presence of soil on an article (10), said method comprising:

introducing a luminescent agent to a detergent during a wash cycle of a washing apparatus, wherein the luminescent agent emits luminescent light, said luminescent agent binding to soil (S) present on the article (10), wherein said luminescent agent is a fluorescent agent and emits a fluorescent light as said luminescent light;

rinsing the article (10) to remove unbound luminescent agent;

exposing the article (10) to a laser light (102) that is continuously pulsed at a modulation frequency;

filtering the light emanating from said article to only allow green light to pass therethrough;

generating light data corresponding to the filtered light, said filtered light including ambient light ( $L_R$ ) reflected by the article (10) and luminescent light ( $L_F$ ) emitted by exciting the luminescent agent bound to the soil (S); and

determining the presence of soil (S) on the article (10) based upon the generated light data, wherein said step of determining the presence of soil (S) includes discriminating between the luminescent light ( $L_F$ ) emitted by the excited luminescent agent bound to the soil (S) and the reflection of the ambient light ( $L_R$ ), wherein green blinking features appearing on a display unit blinking at the modulation frequency of the light source are indicative of the soil,

wherein the modulation frequency of said light source (102) is lower than an emission frequency of a source of ambient light.

12. A method according to claim 11, wherein said modulation frequency of said light source is around 10 Hz.

13. A method according to claim 11, wherein said luminescent agent is bio-compatible.

14. A method according to claim 11, wherein said fluorescent agent is fluorescein having a concentration in the range of about 0.001 mM to 90 mM.

15. A method according to claim 11, wherein said soil (S) is an organic residue including one or more of the following: blood, fat, mucous, lipids, carbohydrates, bone, hair, protein, and food product.

## Patentansprüche

1. Schmutznachweissystem (30A) zum Nachweisen des Vorhandenseins von Schmutz auf einem Artikel (10), wobei das Schmutznachweissystem (30A) umfasst:

eine Abtasteinheit (80A) zum Abtasten des Artikels mit einem Lumineszenzmittel, das an auf dem Artikel vorhandenen Schmutz gebunden ist, wobei das Lumineszenzmittel Lumineszenzlicht mit einer Wellenlänge von sichtbarem Licht emittiert, wobei das Lumineszenzmittel ein Fluoreszenzmittel ist und ein Fluoreszenzlicht als das Lumineszenzlicht emittiert, wobei die Abtasteinheit über eine Oberfläche des Artikels bewegbar ist, wobei die Abtasteinheit umfasst:

eine Laserlichtquelle (100) zum Erzeugen eines Lichts, das kontinuierlich mit einer Modulationsfrequenz EIN und AUS gepulst wird, um auf den Artikel (10) aufzutreffen, wobei die Modulationsfrequenz des von der Lichtquelle erzeugten Lichts niedriger ist als eine Emissionsfrequenz einer Umgebungslichtquelle, die auf den Artikel auftrifft,

einen Lichtfilter (112A), der nur grünes Licht durchlässt,

einen Detektor (90) zum Erfassen elektromagnetischer Strahlung, die von dem Artikel (10) ausgeht und durch den Lichtfilter (112A) gefiltert wird, und zum Erzeugen von entsprechenden Lichtdaten, wobei der Detektor (90) mit einer Bildfrequenz arbeitet, die höher ist als die Modulationsfrequenz des von der Lichtquelle (100) erzeugten Lichts, und

eine Steuereinheit (40) zum Empfangen der von dem Detektor (90) erzeugten Lichtdaten, um das Vorhandensein von Schmutz auf dem Artikel (10) zu bestimmen, wobei die Steuereinheit eine Anzeigeeinheit zum Anzeigen von (i) grün blinkenden Merkmalen, die auf der Anzeigeeinheit mit der den Schmutz anzeigenden Modulationsfrequenz blinken, und (ii) nicht blinkenden Merkmalen oder blinkenden Merkmalen, die auf der Anzeigeeinheit mit anderen Frequenzen als der das von dem Artikel reflektierte Umgebungslicht anzeigenden Modulationsfrequenz blinken, aufweist.

2. Schmutznachweissystem (30A) nach Anspruch 1, wobei die Abtasteinheit (80A) einen dichroitischen Strahlteiler enthält, der das von der Lichtquelle er-

zeugte Licht reflektiert und das reflektierte Umgebungslicht und das emittierte Fluoreszenzlicht durchlässt.

3. Schmutznachweissystem (30A) nach Anspruch 1, wobei das Fluoreszenzmittel Fluorescein ist. 5
4. Schmutznachweissystem (30A) nach Anspruch 3, wobei die Fluorescein-Konzentration im Bereich von etwa 0,001 mM bis 90 mM liegt. 10
5. Schmutznachweissystem (30A) nach Anspruch 1, wobei das Fluoreszenzmittel an Proteine bindet.
6. Schmutznachweissystem (30A) nach Anspruch 1, wobei das Fluoreszenzmittel biokompatibel ist. 15
7. Schmutznachweissystem (30A) nach Anspruch 1, wobei der Laser eine Laserdiode ist, die vorwiegend Licht bei Wellenlängen von 488 nm emittiert. 20
8. Schmutznachweissystem (30A) nach Anspruch 1, wobei der Detektor (90) einen CMOS-Bildsensor oder einen CCD-Bildsensor enthält. 25
9. Schmutznachweissystem (30A) nach Anspruch 1, wobei die Steuereinheit (40) eine Inspektionskammer mit mindestens einer Abtasteinheit (80A) darin und/oder einen Audioausgang (48) aufweist, um eine hörbare Rückkopplung bereitzustellen, wenn Schmutz erfasst wird. 30
10. Schmutznachweissystem (30A) nach Anspruch 1, wobei der Artikel ein chirurgisches Instrument aus rostfreiem Stahl ist. 35
11. Verfahren zum Nachweis des Vorhandenseins von Schmutz auf einem Gegenstand (10), wobei das Verfahren umfasst:

Einführen eines Lumineszenzmittels in ein Waschmittel während eines Waschzyklus einer Waschanlage, wobei das Lumineszenzmittel Lumineszenzlicht emittiert, wobei das Lumineszenzmittel an Schmutz (S) bindet, der auf dem Artikel (10) vorhanden ist, wobei das Lumineszenzmittel ein Fluoreszenzmittel ist und ein Fluoreszenzlicht als das Lumineszenzlicht emittiert;

Spülen des Artikels (10), um ungebundenes Lumineszenzmittel zu entfernen;

Belichten des Artikels (10) mit einem Laserlicht (102), das kontinuierlich mit einer Modulationsfrequenz gepulst wird;

Filtern des von dem Artikel ausgehenden Lichts, um nur grünes Licht durchzulassen;

Erzeugen von Lichtdaten, die dem gefilterten Licht entsprechen, wobei das gefilterte Licht

Umgebungslicht ( $L_R$ ), das von dem Artikel (10) reflektiert wird, und Lumineszenzlicht ( $L_F$ ) enthält, das durch Anregen des an den Schmutz (S) gebundenen Lumineszenzmittels emittiert wird;

und

Bestimmen des Vorhandenseins von Schmutz (S) auf dem Artikel (10) auf der Grundlage der erzeugten Lichtdaten, wobei der Schritt des Bestimmens des Vorhandenseins von Schmutz (S) das Unterscheiden zwischen dem Lumineszenzlicht ( $L_F$ ), das von dem angeregten, an den Schmutz (S) gebundenen Lumineszenzmittel emittiert wird, und der Reflexion des Umgebungslichts ( $L_R$ ) umfasst, wobei grün blinkende Merkmale, die auf einer mit der Modulationsfrequenz der Lichtquelle blinkenden Anzeigeeinheit erscheinen, auf den Schmutz hinweisen, wobei die Modulationsfrequenz der Lichtquelle (102) niedriger ist als eine Emissionsfrequenz einer Umgebungslichtquelle.

12. Verfahren nach Anspruch 11, wobei die Modulationsfrequenz der Lichtquelle etwa 10 Hz beträgt.

13. Verfahren nach Anspruch 11, wobei das Lumineszenzmittel biokompatibel ist.

14. Verfahren nach Anspruch 11, wobei das Fluoreszenzmittel Fluorescein mit einer Konzentration im Bereich von etwa 0,001 mM bis 90 mM ist.

15. Verfahren nach Anspruch 11, wobei der Schmutz (S) ein organischer Rückstand ist, der einen oder mehrere der folgenden Stoffe enthält: Blut, Fett, Schleim, Lipide, Kohlenhydrate, Knochen, Haar, Protein und Nahrungsmittelprodukt.

#### 40 Revendications

1. Système de détection de boue (30A) pour détecter la présence de boue sur un article (10), le système de détection de boue (30A) comprenant :

une unité de balayage (80A) pour balayer l'article avec un agent luminescent lié à la boue présente sur l'article, l'agent luminescent émettant de la lumière luminescente à une longueur d'onde de lumière visible, ledit agent luminescent étant un agent fluorescent et émettant une lumière fluorescente en tant que dite lumière luminescente, l'unité de balayage étant mobile sur une surface de l'article, ladite unité de balayage incluant :

une source de lumière laser (100) pour produire une lumière qui est pulsée en continu sur ON et OFF à une fréquence de modulation pour être incidente sur l'article (10), la fréquence de mo-



- dulation de la lumière produite par la source de lumière étant inférieure à une fréquence d'émission d'une source de lumière ambiante incidente sur l'article,  
 un filtre à lumière (112A) qui ne permet le passage que de lumière verte,  
 un détecteur (90) pour détecter la radiation électromagnétique émanant dudit article (10) qui est filtrée par le filtre à lumière (112A) et générer des données de lumière lui correspondant, ledit détecteur (90) fonctionnant à une vitesse de trame supérieure à la modulation de fréquence de la lumière produite par la source de lumière (100) et  
 une unité de commande (40) pour recevoir les données de lumière générées par le détecteur (90) afin de déterminer la présence de boue sur l'article (10), ladite unité de commande incluant une unité d'affichage pour afficher (i) des configurations clignotantes vertes qui clignotent sur l'unité d'affichage à la fréquence de modulation indicative de la boue et (ii) des configurations non clignotantes ou des configurations clignotantes qui clignotent sur l'unité d'affichage à des fréquences autres que la fréquence de modulation indicative de la lumière ambiante réfléchie par l'article.
2. Système de détection de boue (30A) selon la revendication 1, dans lequel ladite unité de balayage (80A) inclut un fractionneur de faisceau dichroïque qui reflète la lumière produite par la source de lumière et laisse passer la lumière ambiante réfléchie et la lumière fluorescente émise.
  3. Système de détection de boue (30A) selon la revendication 1, dans lequel ledit agent fluorescent est de la fluorescéine.
  4. Système de détection de boue (30A) selon la revendication 3, dans lequel la concentration de ladite fluorescéine est dans la plage d'environ 0,001 mM à 90 mM.
  5. Système de détection de boue (30A) selon la revendication 1, dans lequel ledit agent fluorescent se lie aux protéines.
  6. Système de détection de boue (30A) selon la revendication 1, dans lequel ledit agent fluorescent est biocompatible.
  7. Système de détection de boue (30A) selon la revendication 1, dans lequel ledit laser est une diode laser qui émet majoritairement de la lumière à des longueurs d'onde de 488 nm.
  8. Système de détection de boue (30A) selon la revendication 1, dans lequel ledit détecteur (90) inclut un capteur d'images CMOS ou un capteur d'images CCD.
  9. Système de détection de boue (30A) selon la revendication 1, dans lequel ladite unité de commande (40) inclut une chambre d'inspection comportant au moins une dite unité de balayage (80A) à l'intérieur et/ou une sortie audio (48) pour fournir une réaction audible si de la boue est détectée.
  10. Système de détection de boue (30A) selon la revendication 1, dans lequel ledit article est un instrument chirurgical en acier inoxydable.
  11. Procédé de détection de la présence de boue sur un article (10), ledit procédé comprenant :
    - l'introduction d'un agent luminescent dans un détergent pendant un cycle de lavage d'un appareil de lavage, l'agent luminescent émettant de la lumière luminescente, ledit agent luminescent se liant à de la boue (S) présente sur l'article (10), ledit agent luminescent étant un agent fluorescent et émettant de la lumière fluorescente en tant que dite lumière luminescente ;
    - rinçage de l'article (10) pour éliminer l'agent luminescent non lié ;
    - exposition de l'article (10) à une lumière laser (102) qui est pulsée en continu à une fréquence de modulation ;
    - filtrage de la lumière émanant dudit article pour permettre seulement à la lumière verte de passer à travers ;
    - génération de données de lumière correspondant à la lumière filtrée, ladite lumière filtrée incluant la lumière ambiante ( $L_R$ ) réfléchie par l'article (10) et la lumière luminescente ( $L_F$ ) émise en excitant l'agent luminescent lié à la boue (S) ;
    - et
    - détermination de la présence de boue (S) sur l'article (10) en se basant sur les données de lumière générées, ladite étape de détermination de la présence de boue (S) incluant la discrimination entre la lumière luminescente ( $L_F$ ) émise par l'agent luminescent excité lié à la boue (S) et la réflexion de la lumière ambiante ( $L_R$ ), les configurations clignotantes vertes apparaissant sur une unité d'affichage clignotant à la fréquence de modulation de la source de lumière étant indicatives de la boue,
    - la fréquence de modulation de ladite source de lumière (102) étant inférieure à une fréquence d'émission d'une source de lumière ambiante.
  12. Procédé selon la revendication 11, dans lequel ladite fréquence de modulation de ladite source de lumière est aux alentours de 10 Hz.

13. Procédé selon la revendication 11, dans lequel ledit agent luminescent est biocompatible.
14. Procédé selon la revendication 11, dans lequel ledit agent fluorescent est de la fluorescéine ayant une concentration dans la plage d'environ 0,001 mM à 90Mm. 5
15. Procédé selon la revendication 11, dans lequel ladite boue (S) est un résidu organique incluant un ou plusieurs des éléments suivants : du sang, de la graisse, des mucosités, des lipides, des glucides, de l'os, des cheveux, des protéines et des produits alimentaires. 10

15

20

25

30

35

40

45

50

55

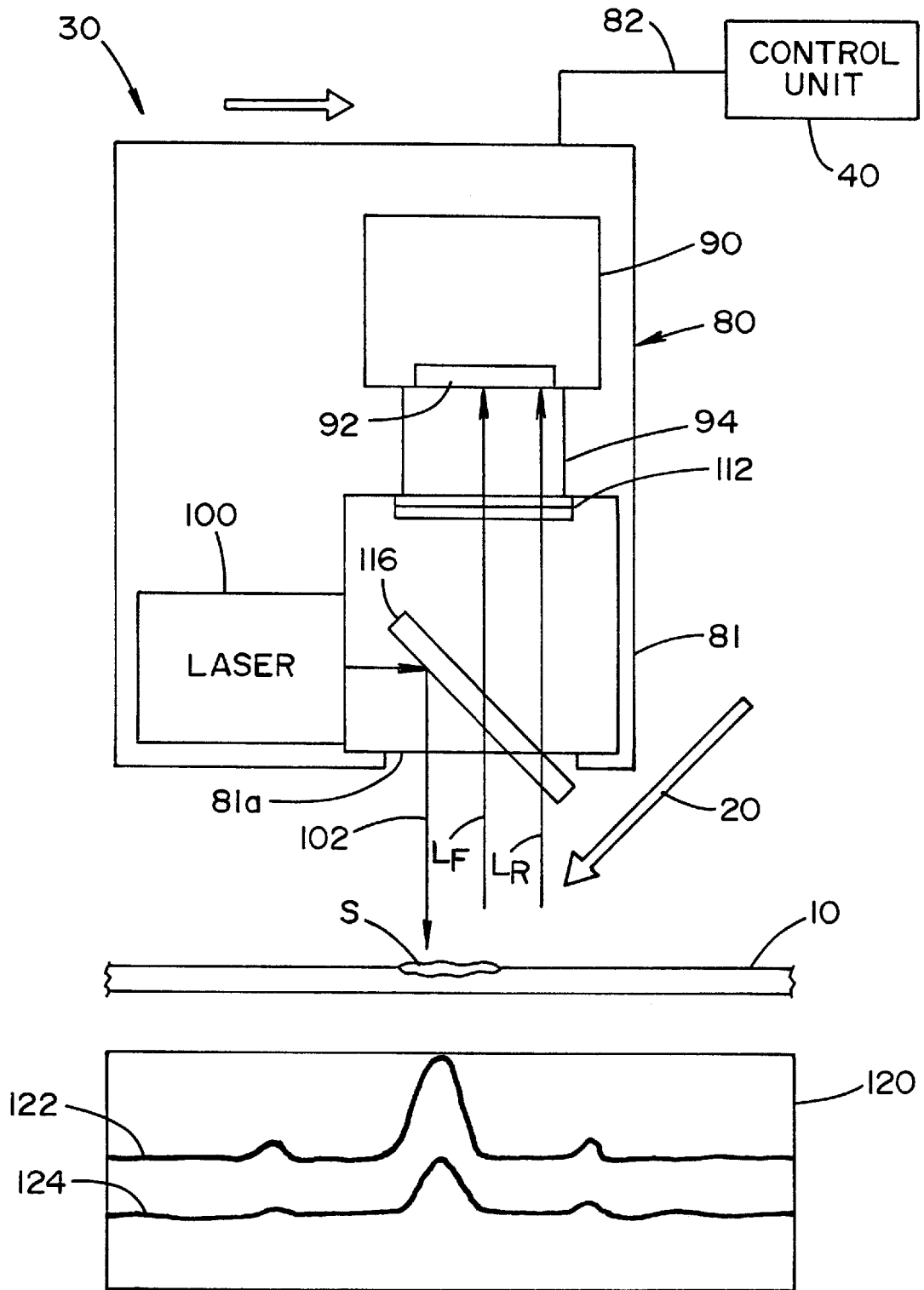

FIG. 1

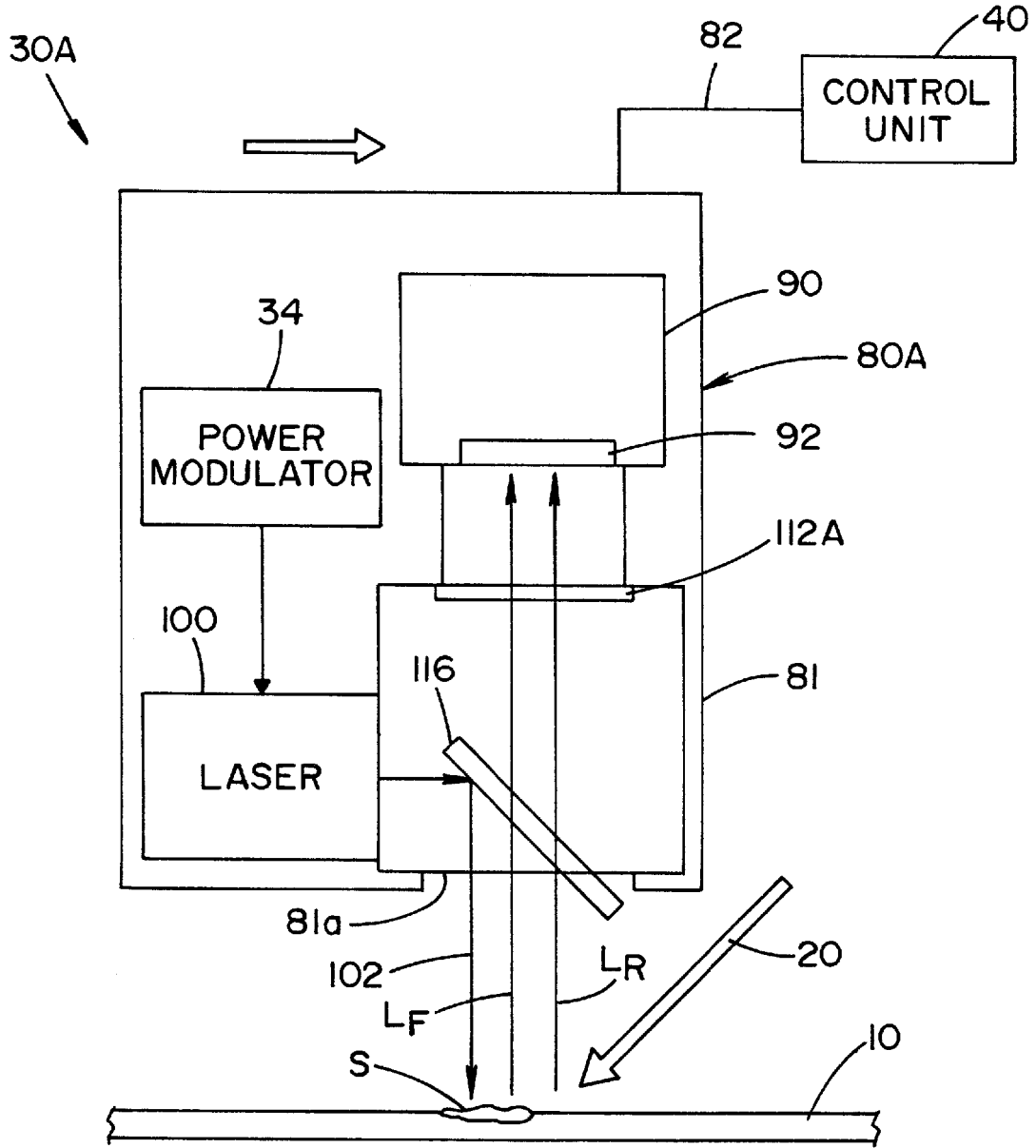

FIG. 2

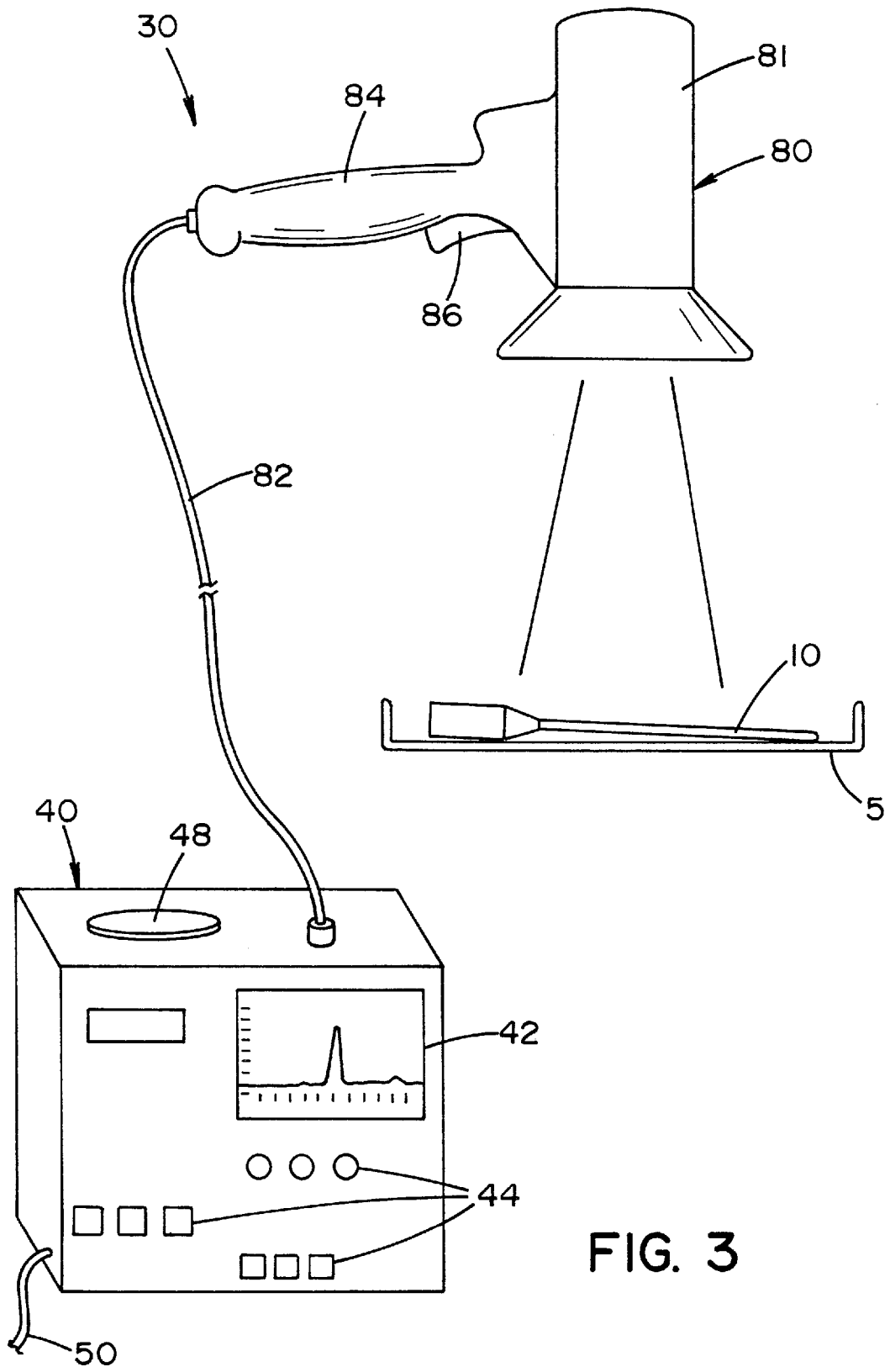

FIG. 3

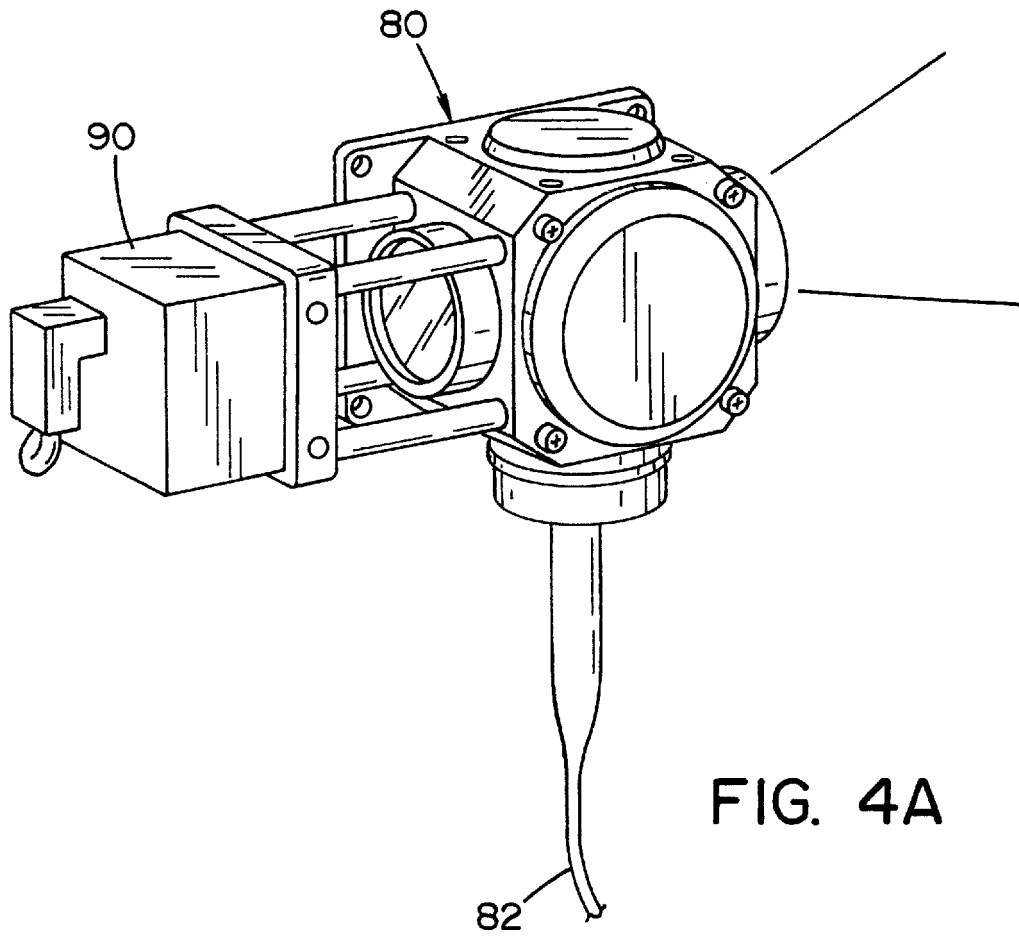

FIG. 4A

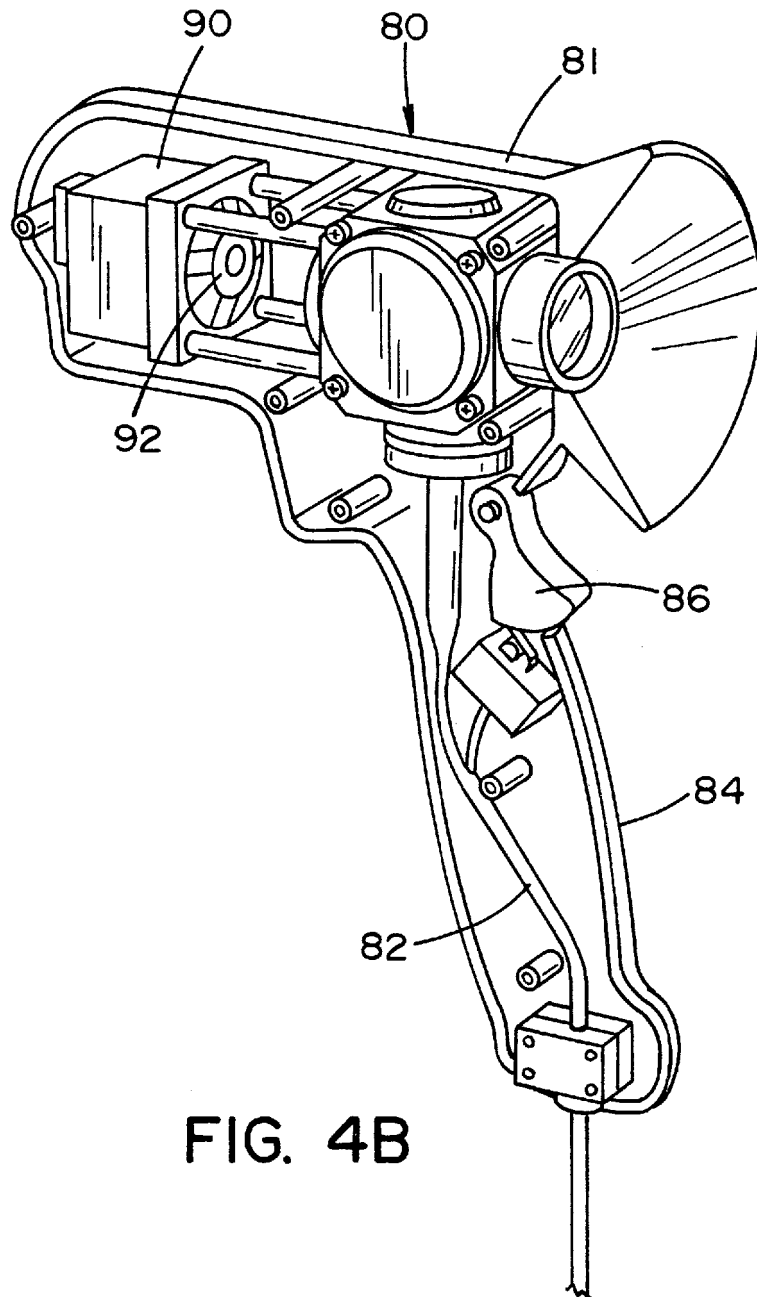

FIG. 4B

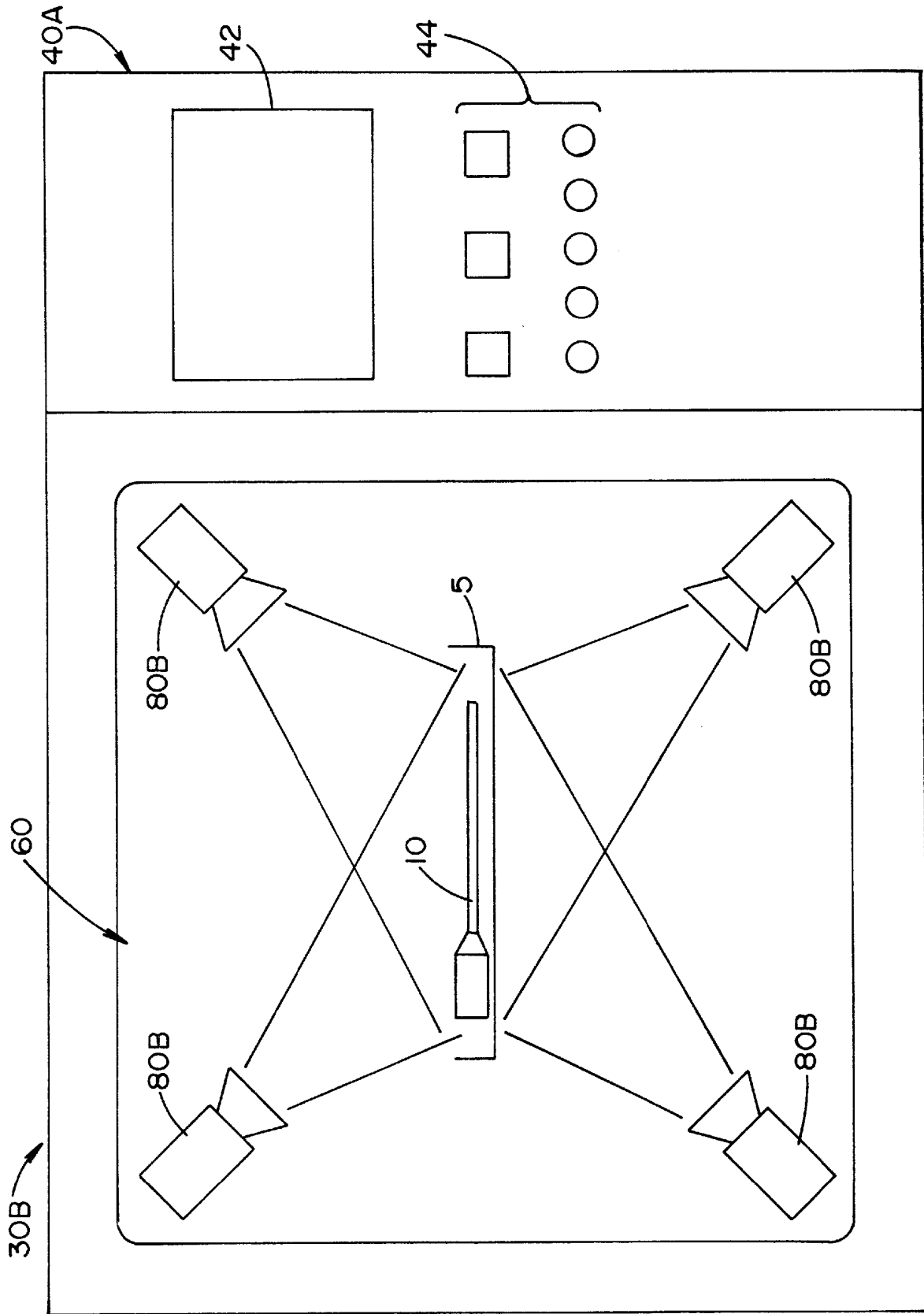

FIG. 5



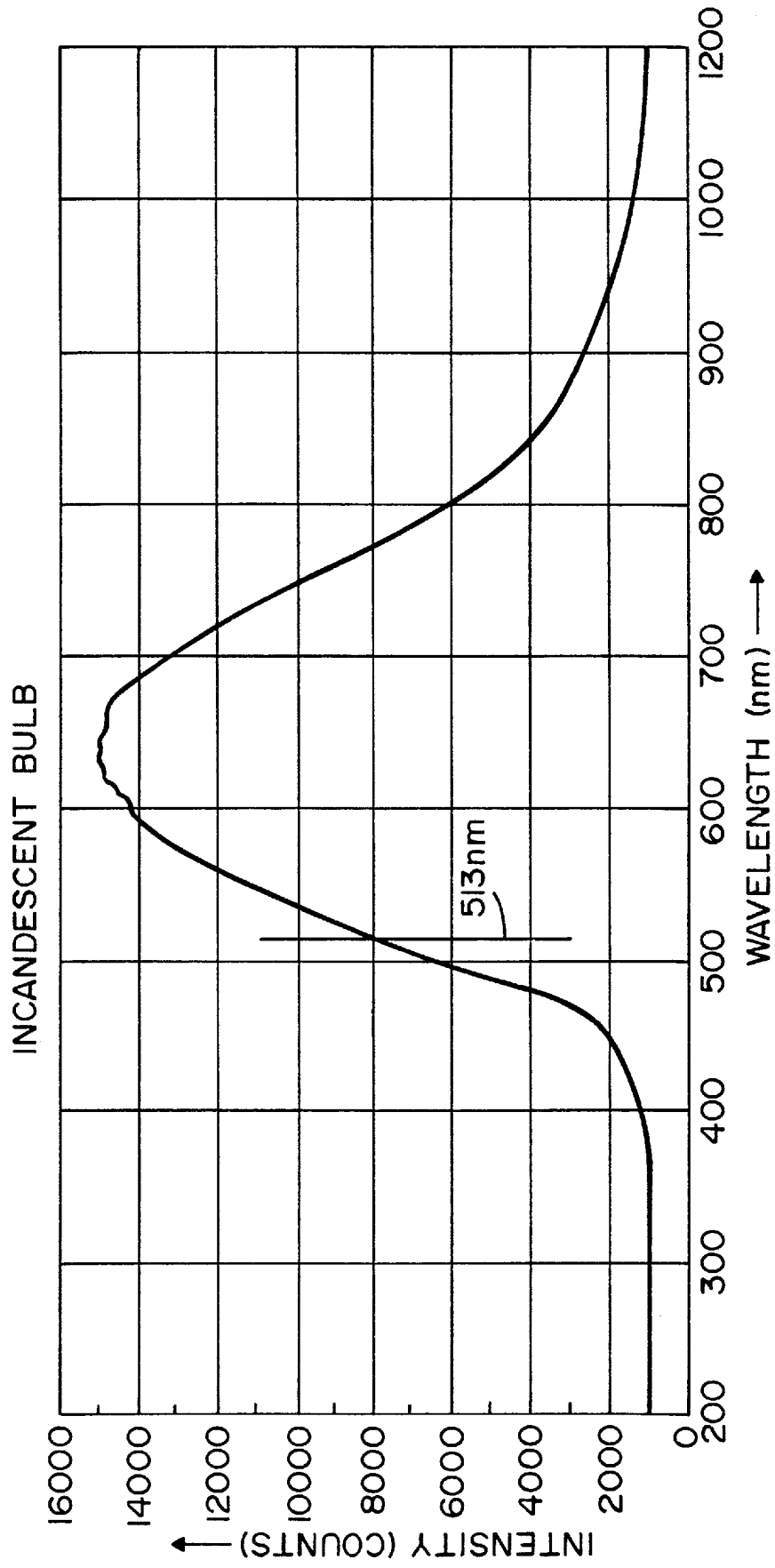

FIG. 6A

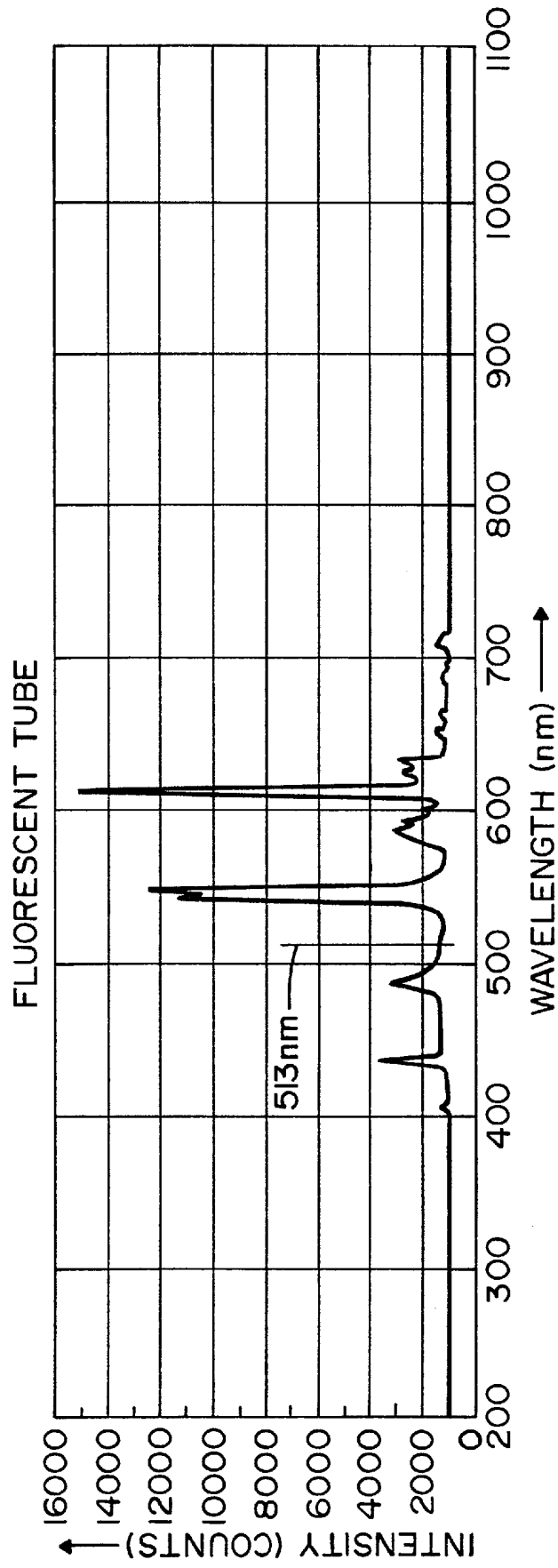

FIG. 6B

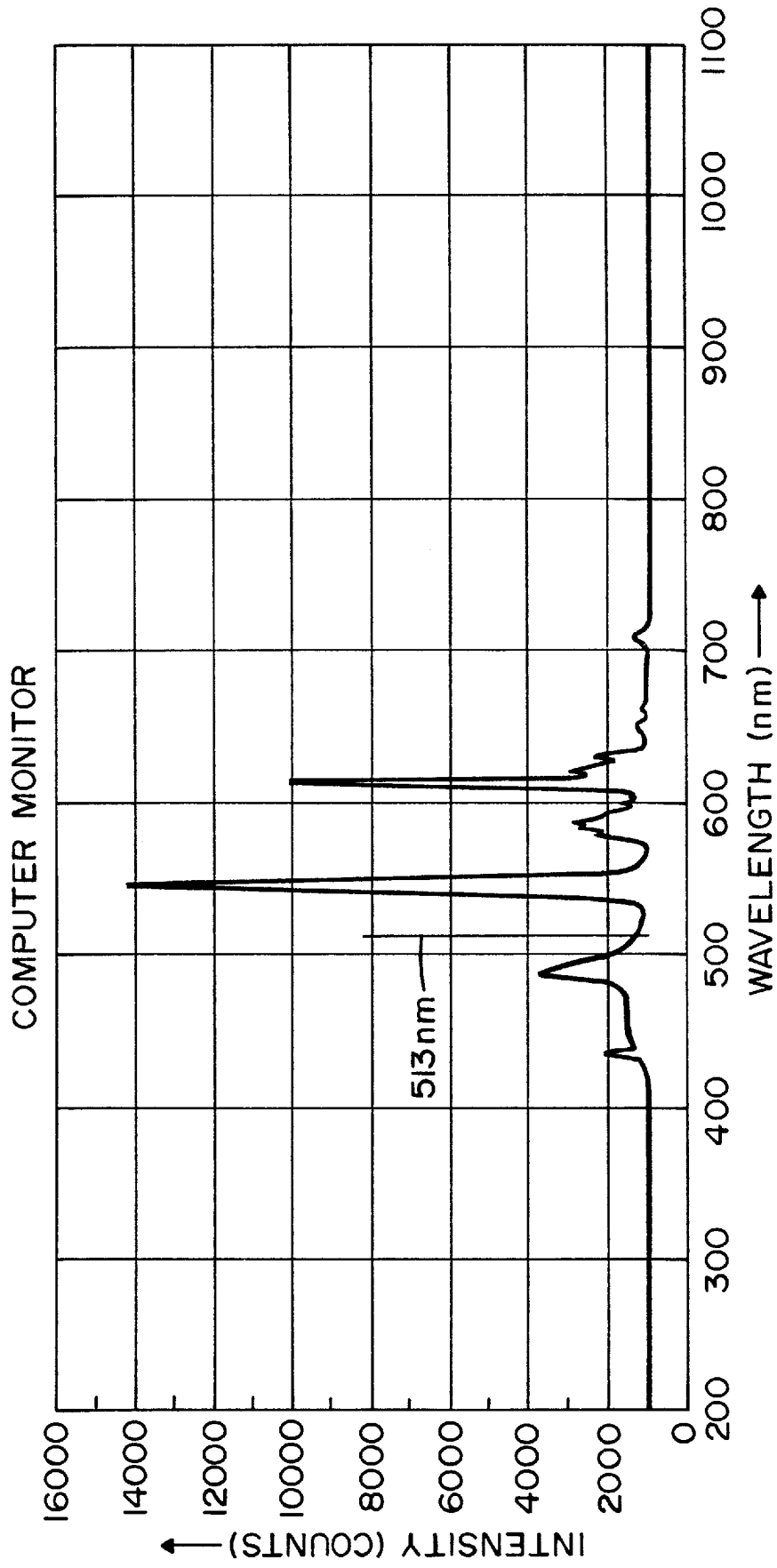

FIG. 6C

**REFERENCES CITED IN THE DESCRIPTION**

*This list of references cited by the applicant is for the reader's convenience only. It does not form part of the European patent document. Even though great care has been taken in compiling the references, errors or omissions cannot be excluded and the EPO disclaims all liability in this regard.*

**Patent documents cited in the description**

- US 20120315627 A1 [0007]
- US 6653 A [0008]
- US 126 B1 [0008]
- US 20030205682 A [0009]