



Office de la Propriété  
Intellectuelle  
du Canada

Un organisme  
d'Industrie Canada

Canadian  
Intellectual Property  
Office

An agency of  
Industry Canada

CA 2293925 C 2004/07/27

(11)(21) **2 293 925**

(12) **BREVET CANADIEN  
CANADIAN PATENT**

(13) **C**

(22) Date de dépôt/Filing Date: 1999/12/31  
 (41) Mise à la disp. pub./Open to Public Insp.: 2001/04/04  
 (45) Date de délivrance/Issue Date: 2004/07/27  
 (30) Priorité/Priority: 1999/10/04 (2,284,946) CA

(51) Cl.Int.<sup>7</sup>/Int.Cl.<sup>7</sup> H01S 5/40  
 (72) Inventeurs/Inventors:  
 LABRANCHE, BRUNO, CA;  
 CHAMPAGNE, YVES, CA;  
 BONNIER, DENI, CA;  
 PARENT, ANDRE, CA  
 (73) Propriétaire/Owner:  
 INSTITUT NATIONAL D'OPTIQUE, CA  
 (74) Agent: ROBIC

(54) Titre : ENSEMBLE DE DIODES LASER  
 (54) Title: LASER DIODE ASSEMBLY

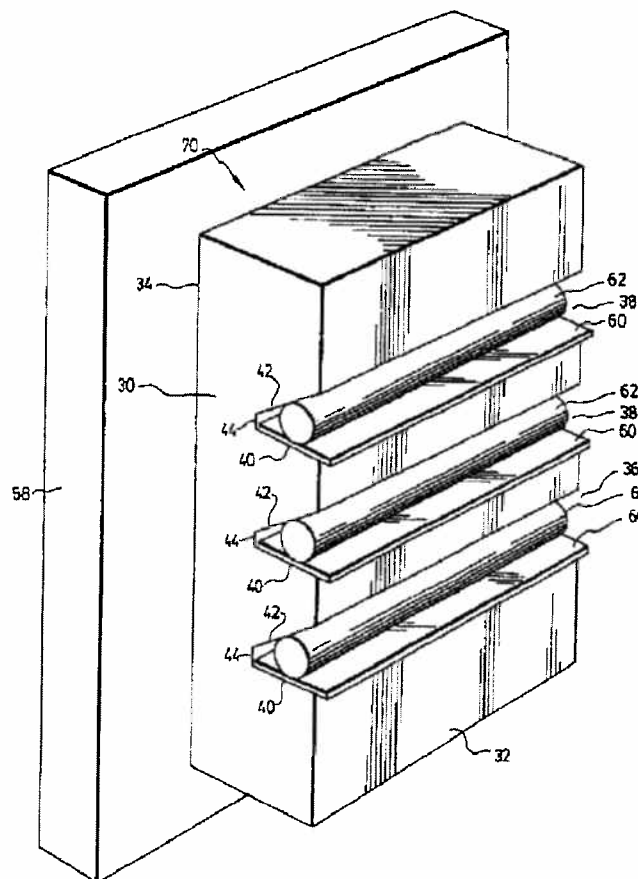

(57) Abrégé/Abstract:

An improved laser diode assembly and a method of making such an assembly are provided. The assembly has a substrate wherein channels are formed to receive laser diodes. The channels have an inwardly tapering shape, with a first side wall



(57) **Abrégé(suite)/Abstract(continued):**

generally perpendicular to the front surface of the substrate and a second side wall at an angle with the first side wall. A metallic coating is provided over the front surface and the side walls of the channels, with a break at the bottom of the channels. Laser diode bars are mounted along the first side wall of each channel, and a conductive body such as a metallic wire is wedged between the laser diode bar and the opposite tilted side wall. The laser diode bars and wires are held in place by a solder layer. Advantageously, this assembly can be manufactured with less stringent fabrication tolerances than with known laser diode arrays.

## LASER DIODE ASSEMBLY

### FIELD OF THE INVENTION

5           The present invention relates to semiconductor laser devices and more particularly concerns a laser diode assembly allowing accurate positioning and alignment of individual laser bars in two-dimensional stacked arrays.

### 10 BACKGROUND OF THE INVENTION

          The numerous advances realized over the last decade in the design, fabrication and processing of high-power semiconductor laser sources, as well as in related technologies, have made these devices the preferred candidates as sources of light for an ever increasing variety of applications.

15           These applications include the optical pumping of solid-state lasers, material processing, light illumination systems, remote sensing, and various medical applications such as in photodynamic therapy and in dermatology. High-power semiconductor laser devices are known in the form of elongated, thin laser diode bars comprising a plurality of individual laser emitters set along

20           an axis parallel to the semiconductor PN junction plane of the emitters. FIG. 1 (prior art) illustrates a schematic drawing of a laser diode bar 10. The axis parallel to the semiconductor PN junction plane is usually referred to as the slow axis 12, while the orthogonal axis along the thickness of the laser diode bar is denoted as the fast axis 14. This terminology comes from the

25           fact that the emitted laser beams 16 diverge strongly along the fast axis direction, thus requiring the use of fast optical elements for efficient collimation of the beams along this axis. The emitted laser beams 16 propagate along the Z direction 18 perpendicular to the plane of the front facet 20 of the laser bar 10. Common laser diode bars comprise typically 10

30           to 50 individual emitters 22, and the total width of the bars is generally set to 1 cm. Each individual emitter 22 has typical dimensions of 50-200  $\mu\text{m} \times$

1  $\mu\text{m}$ , and they are represented by the small filled rectangles in FIG. 1. The  
thickness of the schematic laser diode bar 10 as illustrated in FIG. 1 is  
greatly exaggerated since it scales in practice to about 1% of the width of  
the bar. The laser cavity length, defined as the spacing between both front  
5 20 and rear 24 cleaved facets, is in the order of 500-1000  $\mu\text{m}$ . Laser diode  
bars made from the AlGaAs material system for emission of laser light in the  
790-860 nm wavelength range can routinely emit tens of Watts of CW  
optical power. Although these output power levels suffice for many  
applications, the need for more powerful semiconductor laser sources is  
10 keenly felt for some highly-demanding applications that offer bright  
perspectives on the marketplace.

An obvious, but nevertheless efficient approach for increasing the  
total output power radiated by a semiconductor laser device is to stack  
several laser diode bars one above the other, thus creating a two-  
15 dimensional array of laser emitters. As it is the case for the laser beams  
escaping from the individual emitters of a laser diode bar, the various laser  
beams emitted from the stacked laser diode bars combine with each other in  
an incoherent manner to give an output beam carrying optical powers that  
can reach hundreds of Watts in CW regime and several kW (peak) during  
20 pulsed operation at low duty cycle. Because of their very small thickness,  
along with their elongated shape along the slow axis direction, it is readily  
seen that a lot of laser diode bars can be stacked along the fast axis  
direction without sacrificing too much of the outstanding compactness of  
semiconductor laser sources. In principle, any desired total output power  
25 radiated from such an array could be obtained simply by stacking a  
sufficient number of laser bars of known output power characteristics, and  
then driving them properly. However, because of the very small size of each  
laser bar combined with their typical wall-plug efficiency attaining around  
40% in the best cases, each Watt of radiated optical output power is  
30 accompanied by about one Watt of wasted heat generated by the laser  
array. This heat must be properly removed away from the laser array, since

most of the characteristics of interest of the radiated output beam are found to be sensitive to the local temperature increase. More importantly, the lifetime of the laser bars dramatically shortens when operated at an excessive temperature. The problem becomes particularly critical for laser bars stacked with a high density and operating CW or pulsed at high duty cycles. As a result, the selected design and method for stacking the laser bars into a two-dimensional array should promote efficient removal of the waste heat (low thermal impedance). In addition, each stacked laser diode bar must be driven with ideally the same current level in order to keep the output beam characteristics as uniform as possible over the whole emitting area of the laser array. Several approaches have been advanced for packaging laser diode bars into stacked arrays, most of them falling into two broad categories, well known in the art as the Rack-and-Stack and Bars-In-Grooves approaches, respectively.

In the Rack-and-Stack packaging technique, the individual laser diode bars are first mounted in submount assemblies comprising some support plates and/or spacer plates bonded together and made from various electrically conductive or insulating materials. The submount assemblies are then stacked one above the other and affixed to a heat sink or cooling means on their back side. The Rack-and-Stack technique is flexible, in the sense that the submount assemblies can be designed following various architectures. The submounts can be tested before final mounting, and some architectures allow replacement of defective submount assemblies without destroying the whole array. Using this method, high-density two-dimensional laser diode arrays with vertical pitch spacing as low as 0.4 mm (stacking density of 2.5 laser bars per mm of height) have been successfully realized. However, the labor-intensive steps required during manufacturing of these arrays as well as the need for a lot of small parts machined with high precision, make these arrays costly laser sources, thus prohibiting their use in applications wherein final cost is of primary concern. Furthermore, the high part count of these arrays along with the several soldering and

bonding steps preclude collimation of the laser output beam using prefabricated microlens arrays, due to the great difficulties in positioning and aligning the mounted laser bars within the tight mechanical tolerances required for efficient and predictable beam collimation. Examples of Rack-&-  
5 Stack architectures for stacked laser diode arrays are disclosed in U.S. Patents no. 4,716,568 (Scifres et al.), 4,719,631 (Conaway), 5,099,488 (Ahrabi et al.), 5,305,344 (Patel), 5,311,530 (Wagner et al.), 5,715,264 (Patel et al.), and 5,764,675 (Juhala).

The Bars-In-Grooves packaging architecture provides highly-integrated  
10 laser diode arrays since the individual laser diode bars are inserted and then soldered into precisely-spaced parallel grooves formed in an electrically insulating substrate material. Prior to mounting the laser bars into the grooves, the upper surface of the substrate and the side walls of the machined grooves must be metallized using techniques well known in the  
15 art, in order to ensure electrical continuity throughout the stack. The very low part count inherent to this technique promotes higher mechanical tolerances for the positioning and alignment of the laser diode bars while giving robust stacked laser arrays. In addition, removal of the waste heat is made easier since both metallized sides of the mounted laser bars are in  
20 close contact with the substrate, the latter being preferably made from a thermally conductive ceramic material like beryllium oxide (BeO). Compared to most of the Rack-&-Stack architectures, packaging laser diode arrays with the Bars-In-Grooves technique is somewhat easier, although the laser diode bars can easily be damaged during their loading into the grooves,  
25 whose width must fit closely (within a few microns) with the thickness of the bars. Deposition of uniform metallic coatings onto the side walls of grooves having typical thickness and depth of 150  $\mu\text{m}$  and 1 mm, respectively, is not a trivial task, and replacement of a defective bar after final mounting and soldering of the array is complicated, if at all possible.  
30 The Bars-In-Grooves technique is disclosed in U.S. Patents no 5,040,187; 5,128,951; 5,284,790 and 5,311,535, all to Karpinski. A laser diode array

fabricated according to a slight variation of this technique and having a curved substrate suited for side pumping of cylindrical solid-state laser rods is disclosed in U.S. Patent no 5,627,850 (Irwin et al.).

5 Some other architectures of laser diode array assemblies that cannot be readily included in either of both basic categories discussed above are taught in the following U.S. Patents: 5,325,384 (Herb et al.), 5,394,426 (Joslin), 5,828,683 (Freitas), 5,835,515 (Huang), 5,835,518 (Mundinger et al.), and 5,909,458 (Freitas et al.).

10 In view of the above prior art, it seems that there is a need for a packaging architecture that could lead to the fabrication of affordable stacked laser diode arrays that may comprise a large number of laser diode bars.

#### OBJECTS AND SUMMARY OF THE INVENTION

15 It is therefore an object of the present invention to provide such a packaging architecture that can lead to the fabrication of affordable stacked laser diode arrays.

20 It is another object of the present invention to provide a packaging architecture allowing accurate registration of stacked laser diode arrays to prefabricated microlens arrays for efficient collimation of the laser output beam.

It is yet another object of the invention to provide a method of manufacturing a laser diode assembly in accordance with such an architecture.

25 Accordingly, the present invention provides a laser diode assembly including a substrate having a major front surface and a major back surface. At least one channel extends in the substrate from the major front surface thereof towards the back surface, and tapering inwardly. Each of the at least one channel has a back wall opposite the major front surface, a first side wall generally perpendicular to the major front surface, and a second side wall at an angle with respect to the first side wall.  
30

The laser diode assembly further includes, for each of the at least one channel:

at least one metallic coating covering the major front surface and at least a portion of the first and second side walls;

5 a laser diode bar mounted in the channel adjacent to the first side wall;

at least one conductive body wedged between the laser diode bar and the second side wall; and

10 holding means for holding the laser diode bar and the conductive body inside the channel.

The present invention also provides a method for making a laser diode assembly. The method comprises steps of:

a) providing a substrate having a major front surface and a major back surface;

15 b) making at least one channel in said substrate from the major front surface thereof towards the back surface and tapering inwardly, said at least one channel having a back wall opposite the major front surface, a first side wall generally perpendicular to the major front surface, and a second side wall at an angle with respect to the first side wall;

20 c) covering the major front surface and at least a portion of the first and second side walls of each of the at least one channel with at least one metallic coating;

d) mounting a laser diode bar in each of the at least one channel, adjacent the first side wall thereof;

25 e) wedging at least one conductive body between the laser diode and the second side wall of each of the at least one channel; and

f) providing holding means for holding the laser diode bar and the conductive body inside the corresponding channel.

30 The present invention and its advantages will be better understood upon reading the following non restrictive description of preferred embodiments thereof, made with reference to the accompanying drawings.



## BRIEF DESCRIPTION OF THE DRAWINGS

FIG. 1 (prior art) is a perspective view of a laser diode assembly as known in the art.

5 FIG. 2A is a cross-sectional side elevation view of a substrate for making a laser diode assembly according to a preferred embodiment of the invention, the substrate being provided with channels with beveled edges.

FIG. 2B is a cross-sectional side elevation view similar to FIG. 2A, showing a substrate provided with channels having non-beveled edges.

10 FIG. 2C is a view of the substrate of FIG. 2A covered with a metallic coating.

FIG. 2D is a cross-sectional side elevation view of a laser diode assembly according to a preferred embodiment of the invention.

15 FIG. 3 is a perspective view of a laser diode assembly according to the embodiment of FIG. 2D.

FIG. 4 is a cross-sectional side elevation view of a laser diode assembly according to another preferred embodiment of the invention.

## DESCRIPTION OF PREFERRED EMBODIMENTS OF THE INVENTION

20 The present invention provides both a laser diode assembly and a method of making such an assembly.

Referring to FIG. 3, there is shown a laser diode assembly according to a first preferred embodiment of the invention. The assembly 70 includes a substrate 30 having a major front surface 32 and a major back surface 25 34. In use, the major back surface 34 is bonded to a suitable heat sink 58 that provides adequate cooling of the assembly 70. At least one channel 38 extends in the substrate 30, from the major front surface 32 towards the back surface 34. Three such channels 38 are represented in FIG. 3, but of course any desired number of channels may be provided. The channels 38 30 are tapering inwardly, and each is defined by a back wall 44 opposite the major front surface 32, a first side wall 40 generally perpendicular to the

major front surface 32, and a second side wall 42 at an angle with respect to the first side wall 40. Optionally, the edge 46 joining the first side wall 40 and the major front surface 32 may be beveled (such a beveled edge is better seen in FIG. 2A).

5 For each channel 38, a metallic coating 50 (shown in FIG. 2C) covers the surrounding parts of the major front surface 32 and at least a portion of the first and second side walls 40 and 42. The metallic coating is continuous over the entire major surface, but breaks 52 into the metallization are formed around the junction between the first side wall 40  
10 and the back wall 44 of the channels 38. These breaks 52 into the metallization prevent electrical shorts between both electrodes of the mounted laser diode bars.

A laser diode bar 60 is mounted in the channel 38, along the first side wall 40. Suitable type of laser diode bars for use with this assembly are well  
15 known in the art. The laser diodes 60 are preferably mounted so their respective P electrode faces the first side wall 40 along which they are set, and their front facet extends parallel to the major front surface 32. At least one conductive body is wedged in each channel 38 between the laser diode 60 and the second side wall 42. Preferably, as shown in FIG. 3, the  
20 conductive body is embodied by a metallic wire 62 which extends parallel to the major front surface 32. In an alternative embodiment, a plurality of such metallic wire 62 may be provided, as shown in FIG. 4. Inserting several wires instead of a single one renders the fabrication process somewhat slower, but the voids in the channels are filled in a more complete manner.  
25 In addition, the use of several wires 80 helps in spreading the mechanical forces over a larger surface of the N electrode of the laser diode bars 60, while increasing the overall electrical contact surface between the laser diode bars 60 and the wires 80. During the soldering step, the melted solder fills in the voids left between the metallic wires, thus giving a more robust  
30 structure along with decreasing the thermal resistance for the heat flowing from the laser diode bar towards the tilted side wall.

Means for holding the laser diode bars 60 and the conductive bodies inside their channels are also provided, and are preferably embodied by a solder layer 68 (shown in FIG. 2D) deposited in each channel 38 from the major front surface 32.

5 Referring to FIGs. 2A to 2D, the basic steps involved in the fabrication process of a laser diode array assembly according to a first embodiment of the present invention may be understood.

The first step a) of the above mentioned method comprises providing a substrate 30 having a major front surface 32 and a major back surface  
10 34. Such a substrate may be seen in FIG. 2A. The major back surface 34 is preferably flat and is affixed, in use, to a suitable heat sink 58 or cooling means for back plane cooling of the laser array assembly.

Step b) includes making at least one channel 38 in the substrate 30 from the major front surface 32 towards the major back surface 34. Each  
15 channel 38 has an inwardly tapering shape defined by a back wall 44 opposite the major front surface 32, and first and second side walls 40 and 42. The first side wall 40 is generally perpendicular to the major front surface 32, whereas the second side wall 42 is at an angle with respect to the first side wall 40. Any number of channels 38 may be made in the  
20 substrate 30, depending on the number of laser diode bars to be mounted in the array. FIG. 2A depicts a substrate 30 in which are formed three channels 38; this substrate 30 would therefore be suited for mounting a three-bar stacked laser diode array.

As a result of the machining of the channels 38, the major front  
25 surface 32 forms a set of elongated ridge structures 36 parallel to each other and whose length corresponds nearly to the width (1 cm) of the laser diode bars to be mounted in the array. The ridge structures 36 extend along the direction perpendicular to the plane of the drawing, so that only their cross-section is visible in FIG. 2A. Consecutive ridges 36 are separated by  
30 channels 38. As shown in FIG. 2A, the cross-section of each ridge structure 36 is identical to each other. The channels 38 are preferably machined so

that the first side walls 40 has a suitable surface finish along with an excellent parallelism between them. Consecutive side walls 40 are spaced by the distance  $P$  that will determine the vertical pitch of the laser array assembly. The vertical pitch  $P$  may range from about 500  $\mu\text{m}$  up to 2-3 mm, and it will be dictated by factors such as the way the channels are machined, the expected operating conditions of the laser array, and the performance of the cooling system. Machining the first side walls 40 with tight mechanical tolerances will ensure that the laser diode bars will be set parallel to each other and that the laser beams emitted from the set of laser diode bars will propagate along the same direction, perpendicular to the major front surface 32 of the substrate 30. This promotes an efficient collimation of the laser beams along the fast axis by using a prefabricated cylindrical microlens array whose spacing between consecutive microlenses is matched to the vertical pitch of the laser array. The second side wall 42 of each channel 38 is tilted with an angle  $\theta$  relative to the plane of the corresponding first side wall 40. Tilting the side walls 42 will serve to relax most of the dimensional tolerances on the small parts to be loaded into the channels along with the laser diode bars.

The depth  $H$  of the channels 38 is preferably adapted to the length (typically around 600-1000  $\mu\text{m}$ ) of the laser diode bars to be mounted into the channels 38, while the width  $W$  of the back wall 44 should preferably be larger than the thickness (typically around 100-150  $\mu\text{m}$ ) of the laser diode bars. Machining the channels so that the back wall 44 is sufficiently wide allows the use of laser diode bars of varying thickness, thus avoiding the need for specifying tight tolerances on the bar thickness. The value of the tilt angle  $\theta$  as well as the exact shape of the second side walls 42 are not critical to the operation of a laser array assembly fabricated according to the present invention. Small tilt angles in the range of  $5^\circ$  to  $30^\circ$  are however preferred to avoid excessive removal of substrate material. Removing a large fraction of material from the front major surface 32 of the substrate 30 will make the ridges 36 more fragile, thus increasing the risk

of breaking some of the ridges during machining, particularly for small (less than about 0.5 mm) values of the vertical pitch  $P$ . In addition, machining very thin ridges 36 results in a less efficient removal of the heat generated by the firing laser diode bars.

5           The substrate 30 as depicted in FIG. 2A is machined out from a single piece of material, and it is therefore said to be monolithic. However, the invention is not limited to the use of a monolithic substrate, although a single piece of material is preferred for reducing as much as possible the number of interfaces with high thermal impedance across the heat flow path  
10 from the laser diode bars up to the heat sink or cooling means to which the laser diode array assembly is attached. The substrate 30 is preferably made from an electrically insulating material to prevent the laser diode bars from being electrically shorted. Furthermore, the substrate material preferably has a good thermal conductivity and its thermal expansion coefficient is  
15 preferably matched to that of the semiconductor material from which the laser diode bars are fabricated. For instance, the thermal expansion coefficient of the AlGaAs material for laser emission within the 790-860 nm wavelength range is about  $6.8 \times 10^{-6}/^{\circ}\text{C}$ . According to the various considerations given above, high-thermally-conductive ceramic materials like  
20 beryllium oxide (BeO) or aluminum nitride (AlN) are outstanding candidates.

The selection of the thickness of the substrate 30 results primarily from a design trade-off between the need for minimizing the overall thermal impedance of the laser array assembly (by using a thinner substrate) and the need for ensuring a sufficient mechanical rigidity to the assembly (by using  
25 a thicker substrate). Substrates with thickness around 2-3 mm are well suited for use in array assemblies comprising laser diode bars with cavity length in the order of 500-1000  $\mu\text{m}$ .

The preferred technique for machining the set of channels 38 in the major front surface 32 of the substrate 30 is to use a programmable dicing  
30 saw. A single custom-shaped saw blade can be used for slicing each channel 38 in a single run, although a more flexible (but slower) technique

would consist of using two different saw blades for slicing each channel. For instance, a first slicing run could be performed with a standard saw blade of suitable thickness to form the first side walls 40 of each channel 38 with the required surface finish, while another custom-shaped saw blade could be used for machining the tilted second side walls 42. Accordingly, the tilted side walls 42 could be formed from a series of slicing runs with progressively decreasing depth. As shown in FIG. 2A, the first side walls 40 may be machined in order to get a small beveled edge 46 that would favor a better wetting of the interface between the P electrode of the laser bar and the first side wall 40 during the solder reflow. Furthermore, machining side walls 40 with beveled edges 46 helps in reducing the risks of breaks in the metallization deposited on otherwise sharp corner edges. It should be noted, however, that the presence of the beveled edges 46 is not essential to the operation of the laser diode array. For instance, a schematic drawing of a substrate that does not include beveled edges but being otherwise identical to that discussed above, is shown in FIG. 2B.

Referring to FIG. 2C, the major front surface 32 and at least a portion of the first and second side walls 40 and 42 of each channel 38 is covered with a metallic coating, in accordance with step c) of the present method. The metallic coating 50 provides electrical continuity between successive laser diode bars mounted in the array and it makes possible the soldering of the laser diode bars to the flat side walls 40. Deposition techniques well known in the art such as vacuum evaporation, electron-beam evaporation, sputtering and electroplating can be used for metallizing the substrate 30. The metallization scheme generally comprises several metallic layers of various types. A first metallic layer should ensure adequate adhesion to the substrate material, while a subsequent metallic layer of high electrical conductivity could be deposited to provide a low electrical resistance path between successive laser diode bars. Finally, a layer made of a solderable base metal compatible with the solder composition could be deposited. FIG. 2C shows that breaks 52 into the metallization are formed around the

junction between the first side wall 40 and the back wall 44 of the channels 38. These metallization breaks 52 prevent electrical shorts between both electrodes of the mounted laser diode bars. The metallization breaks 52 can be realized by using proper masking techniques during deposition of the metallic coatings. A shallow slicing cut made into the back wall 44 of each channel of the metallized substrate can be used to form the metallization breaks 52 as well. It is worth noting that both sides 54 of the substrate 30 should not be metallized, otherwise the laser diode bars would be shorted. Solder pads 56 are bonded to the metallized substrate 30, and power leads 58 are then soldered to the pads 56 for electrical connection of the laser array assembly to a remote power supply. The solder pads 56 could be located on both upper and lower parts of the front major surface 32 of the substrate 30, although the position of the solder pads 56 as illustrated in FIG. 2C is preferred when the laser array assembly is to be registered to a microlens holder for collimation of the output laser beam.

Referring to FIG. 2D, the next step d) of the method according to the present invention includes mounting a laser diode bar 60 along the first wall 40 of each channel 38. Each laser diode bar 60 is mounted in such a way that its front facet 64 from which the laser beam 66 is radiated out is parallel to the front major surface 32 of the substrate 30. The front facets 64 of the mounted laser diode bars 60 should lie within the same plane to enable the use of a prefabricated array of microlenses for collimation of the laser beams. In addition, the front facets 64 of the laser diode bars 60 preferably protrude slightly from the plane of the metallized major front surface 32 of the substrate 30 to help in reducing the risk of damage to the front facets 64 during solder reflow and during subsequent cleaning steps. Each laser diode bar 60 is mounted so that its P electrode is soldered to the first side wall 40 (P-side down configuration) to maximize removal of the waste heat.

Still referring to FIG. 2D, step e) involves wedging at least one conductor body between the laser diode bar 60 and the second side wall 42

of each channel 38. In the illustrated embodiment, the conductor body is a thin metallic wire 62 of circular cross-section. The metallic wire 62 is pushed into the channel 38 until it comes into contact with the N electrode of the laser bar 60 and with the metallized tilted side wall 42. The fact that the side wall 42 is tilted permits the use of wires of varying diameters while providing safe loading of the wires to avoid damages to the laser diode bars 60 during the operation. The purpose of the metallic wire 62 is twofold. First, it serves to hold the laser diode bar 60 in place before soldering it to the side wall 40. Secondly, it provides electrical continuity between the N electrode of the laser diode bar 60 and the metallized tilted side wall 42. The wires 62 can be made from any easily solderable metal such as silver, gold or copper. The high thermal conductivity of these metals also favours the removal of some part of the heat generated by the laser diode bars 60. The final length of the metallic wires 62 loaded into the channels is set equal to the width of the laser diode bars 60 (typically 1 cm). However, it has been found that loading of the metallic wires 62 is made easier by using longer wires that are cut at their definitive length only after the final soldering step of the array has been completed. In this way, both ends of the metallic wires 62 can be attached to a customized alignment tool that can provide a convenient stretching force on the wires during their loading. Such an alignment tool can also provide an additional force directed onto the laser diode bars, thus securing them against the flat side walls 40 prior to the final soldering step.

Finally, still with reference to FIG. 2D, step f) includes providing holding means for holding the laser diode bar 60 and conductive body inside the corresponding channel 38. In the preferred embodiment, a solder layer 68 is deposited into each channel 38, preferably from a single soldering step. Soft solders having a low melting temperature like indium-based alloys are preferred. The force exerted by the wedged metallic wires 62 onto the laser diode bars 60 helps in improving the solder bond and prevents accidental misalignments of the bars 60 during solder reflow. Droplets of



solder can be first deposited on the front major surface 32 between adjacent laser bars of the array assembly. During the soldering step, the whole laser array assembly is placed on or over a temperature-controlled heat plate. The array assembly is oriented so that the front major surface 32 is horizontal. The temperature is then increased until it slightly exceeds the melting temperature of the solder, and the maximum temperature is maintained long enough to ensure complete reflow of the solder droplets. Part of the solder will flow evenly on the front major surface 32, thus helping to reduce the electrical resistance between adjacent laser diode bars. As it is seen in FIG. 2D, the metallic wires 62 are generally not visible from the front major surface 32 of the array since they are buried into the solder 68. The void left between the beveled edge 46 of the first side wall 40 and the upper part of the P electrode of the laser diode bars 60 is filled by solder 68 as well.

As compared to laser diode array architectures of the Rack-&-Stack type, a laser diode array assembly fabricated according to the spirit of the present invention would be more suited for beam collimation by a prefabricated array of microlenses mounted in their own support. This practice for collimating the laser beams radiated out from stacked laser diode arrays reveals itself as being more economical than collimating each laser diode bar individually. On the other hand, it is well known that the successful use of prefabricated microlens arrays requires accurate positioning and alignment of the laser diode bars. These tight positioning and alignment tolerances should be easier to get from a fabrication technique based on the present invention since high-precision machining is really required only for the first side walls 40 of the channels 38 to which the laser diode bars are soldered. As a matter of fact, the other mechanical tolerances are not critical to the efficient operation of the laser diode array assembly. The laser diode array assemblies obtained following the approach described herein are robust and less sensitive to vibrations since they rely on a monolithic substrate. In addition, the part count of this approach is

low, although not as low as for the array assemblies fabricated from the Bars-In-Grooves technique. The overall thermal impedance of a laser diode array assembly of the present invention is expected to be approximately midway between those of the Rack-&-Stack techniques and of the Bars-In-Grooves technique. As compared to the Bars-In-Grooves method, the technique described herein should result in higher fabrication yields by reducing the potential damages to the laser diode bars during mounting of the array, since the laser diode bars do not need to be loaded between two tightly-spaced side walls. In addition, there is no need for requesting tight tolerances on the thickness of the laser diode bars to be mounted in the array because the channels formed between adjacent ridges are relatively large. Soldering the laser diode bars to precisely-machined side walls on which uniform metallic coatings are deposited should result in more efficient collimation of laser diode arrays fabricated according to the present invention. This contrasts with the Bars-In-Grooves technique. In this latter technique, it is not a trivial task to get a uniform deposition of metallic coatings over the whole surface of the side walls of the narrow grooves. Moreover, the clearance required for insertion of the laser bars into the grooves can lead to a slight tilt of the laser bars relative to the side walls of the grooves, thus degrading the collimation efficiency of an array fabricated from the Bars-In-Grooves technique.

The surface finish of the tilted second side walls as well as their exact shape do not affect the correct operation of the laser diode arrays. As a result, machining these side walls is easy and fast. These specially-shaped side walls allow the loading of low-cost metallic wires of various diameters into the channels. This represents a considerable improvement as compared to most other array architectures that require the use of small parts machined with high precision. Depending on the outer diameter of the wires, more than one wire can be loaded into the channels. Insertion of the laser diode bars and of the metallic wires into the channels can be made relatively easily and quickly by using appropriate tooling, and the various

parts of the array can be soldered in a single step. As a result, the fabrication cost of laser diode array assemblies according to the principle of the present invention should be quite competitive with that of laser diode arrays based on well-developed fabrication techniques.

5           Of course, numerous changes could be made to the preferred embodiment disclosed hereinabove without departing from the scope of the invention as defined in the appended claims.

## WHAT IS CLAIMED IS:

## 1. A laser diode assembly comprising:

5 a substrate having a major front surface and a major back surface, at least one channel extending in said substrate from the major front surface thereof towards the back surface and tapering inwardly, each of said at least one channel having a back wall opposite the major front surface, a first side wall generally perpendicular to the major front surface, and a second side wall at an angle with respect to the first side wall;

10 said laser diode assembly further comprising, for each of the at least one channel:

at least one metallic coating covering the major front surface and at least a portion of the first and second side walls;

15 a laser diode bar mounted in the channel adjacent to the first side wall;

at least one conductive body wedged between the laser diode bar and the second side wall; and

20 holding means for holding the laser diode bar and the conductive body inside the channel.

2. A laser diode assembly according to claim 1, wherein the at least one conductive body in each channel comprises a metallic wire, said metallic wire extending along a direction generally parallel to the major front surface.

25 3. A laser diode assembly according to claim 1, wherein the at least one conductive body in each channel comprises a plurality of metallic wires, said metallic wires each extending along a direction generally parallel to the major front surface.

4. A laser diode assembly according to claim 1, wherein the holding means comprise a solder layer deposited in each channel from the major front surface.

5 5. A laser diode assembly according to claim 1, wherein the major front surface and the first side wall of each of the at least one channel meet to form an edge, said edge being beveled.

10 6. A laser diode assembly according to claim 1, further comprising cooling means connected to the major back surface of the substrate.

15 7. A laser diode assembly according to claim 1, wherein the laser diode bar mounted in each of the at least one channel has a P electrode and an N-electrode, the P electrode facing the first side wall.

20 8. A laser diode assembly according to claim 1, wherein the laser diode mounted in each of the at least one channel has a front facet, said front facet extending parallel to the major front surface and having a laser beam radiating therefrom.

25 9. A laser diode assembly according to claim 1, wherein the major front surface of the substrate and the back wall of each of the at least one channel are separated by a distance between approximately 600 and 1000 micrometers.

10. A laser diode assembly according to claim 1, wherein the second side wall of each of the at least one channel is at an angle of between 5 and 30 degrees with respect to the corresponding first side wall.

11. A laser diode assembly according to claim 1, wherein the substrate is made from an electrically insulating material having an adequate thermal conductivity.

5 12. A laser diode assembly according to claim 11, wherein the electrically insulating material is chosen from the group consisting of beryllium oxide and aluminum nitride.

10 13. A laser diode assembly according to claim 1, wherein said assembly includes a plurality of channels, each of said channels being parallel.

14. A method of making a laser diode assembly, the method comprising steps of:

15 a) providing a substrate having a major front surface and a major back surface;

b) making at least one channel in said substrate from the major front surface thereof towards the back surface and tapering inwardly, said at least one channel having a back wall opposite the major front surface, a first side wall generally perpendicular to the major front surface, and a second side wall at an angle with respect to the first side wall;

20

c) covering the major front surface and at least a portion of the first and second side walls of each of the at least one channel with at least one metallic coating;

d) mounting a laser diode bar in each of the at least one channel, adjacent the first side wall thereof;

25

e) wedging at least one conductive body between the laser diode and the second side wall of each of the at least one channel; and

f) providing holding means for holding the laser diode bar and the conductive body inside the corresponding channel.

15. A method according to claim 14, wherein step b) comprises slicing each channel in a single run with a custom-shaped saw blade.
16. A method according to claim 14, wherein, for each of the at least one  
5 channel, step b) comprises the sub-steps of:
- i) machining the first side wall with a standard saw blade; and
  - ii) machining the second side wall with a custom-shaped saw blade.
17. A method according to claim 14, wherein, for each of the at least one  
10 channel, step b) comprises the sub-steps of:
- i) machining the first side wall; and
  - ii) machining the second side wall through a series of slicing runs of a progressively decreasing depth.
- 15 18. A method according to claim 14, wherein step c) comprises depositing each of the at least one metallic coating with a technique chosen from the group consisting of vacuum evaporation, electron-beam evaporation, sputtering and electroplating.
- 20 19. A method according to claim 14, wherein step f) comprises depositing a solder layer in each of the at least one channel.

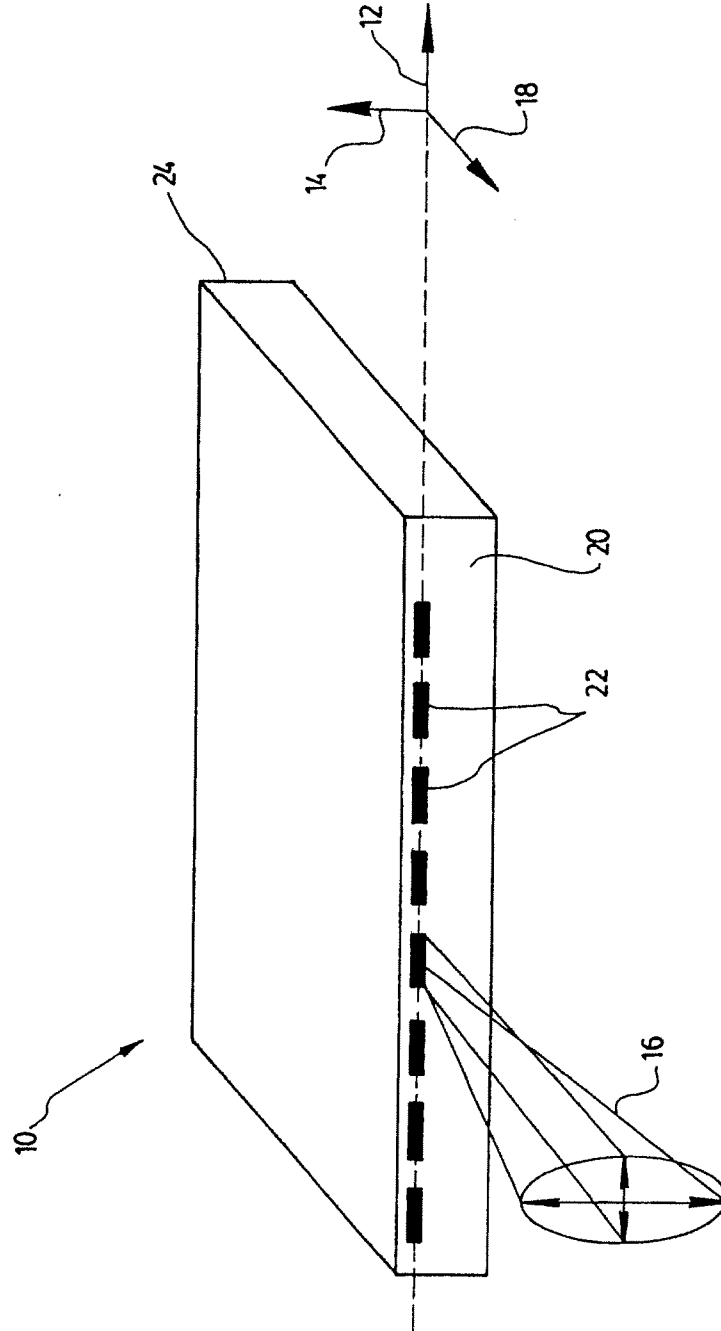

FIG. 1  
(PRIOR ART)



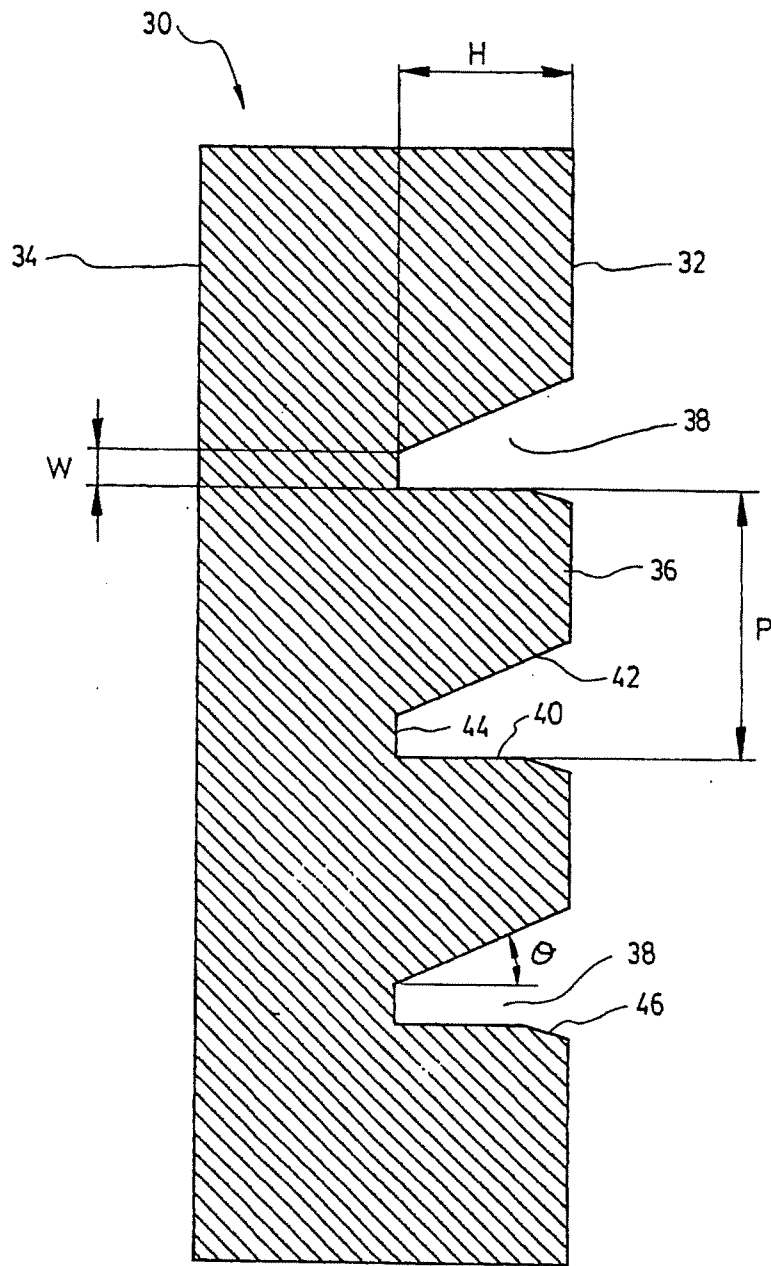

FIG. 2A

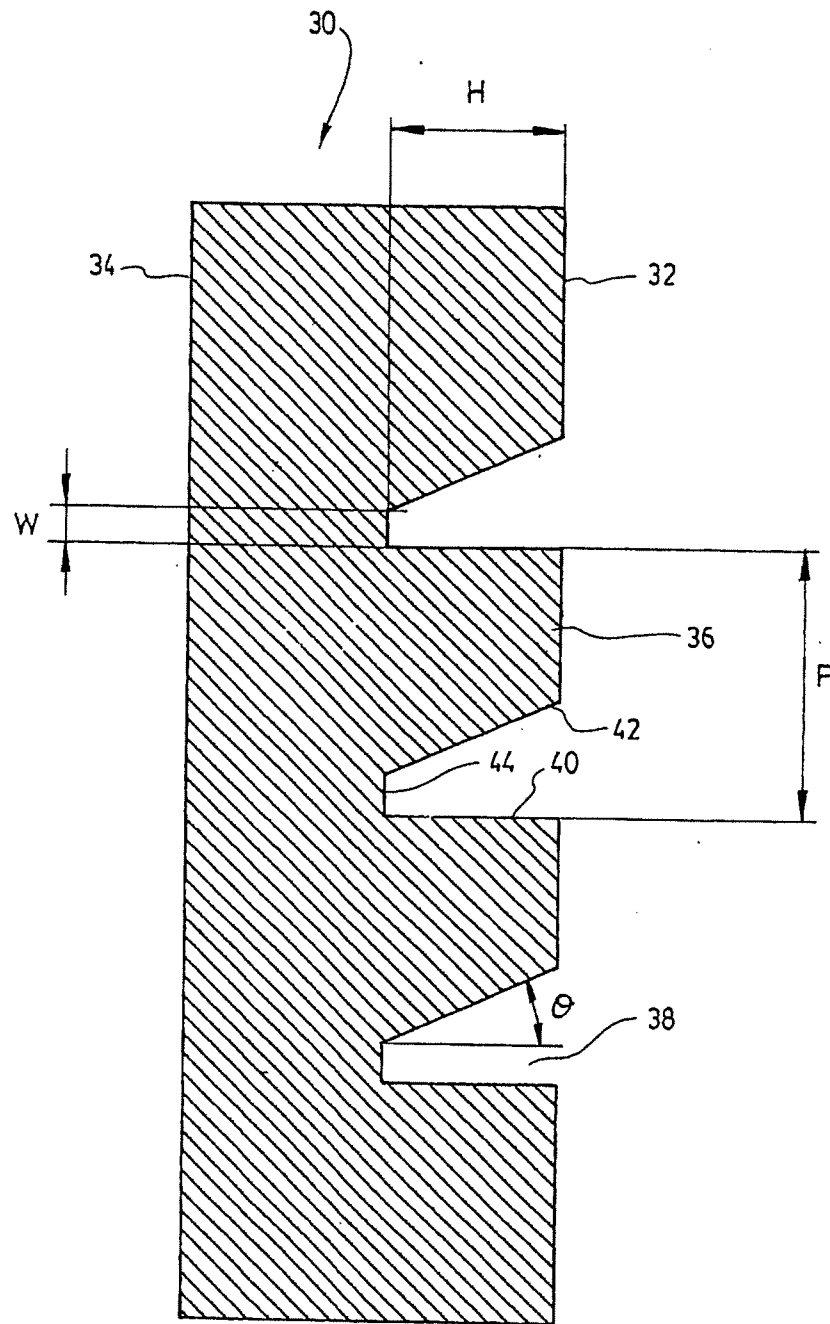

FIG. 2B

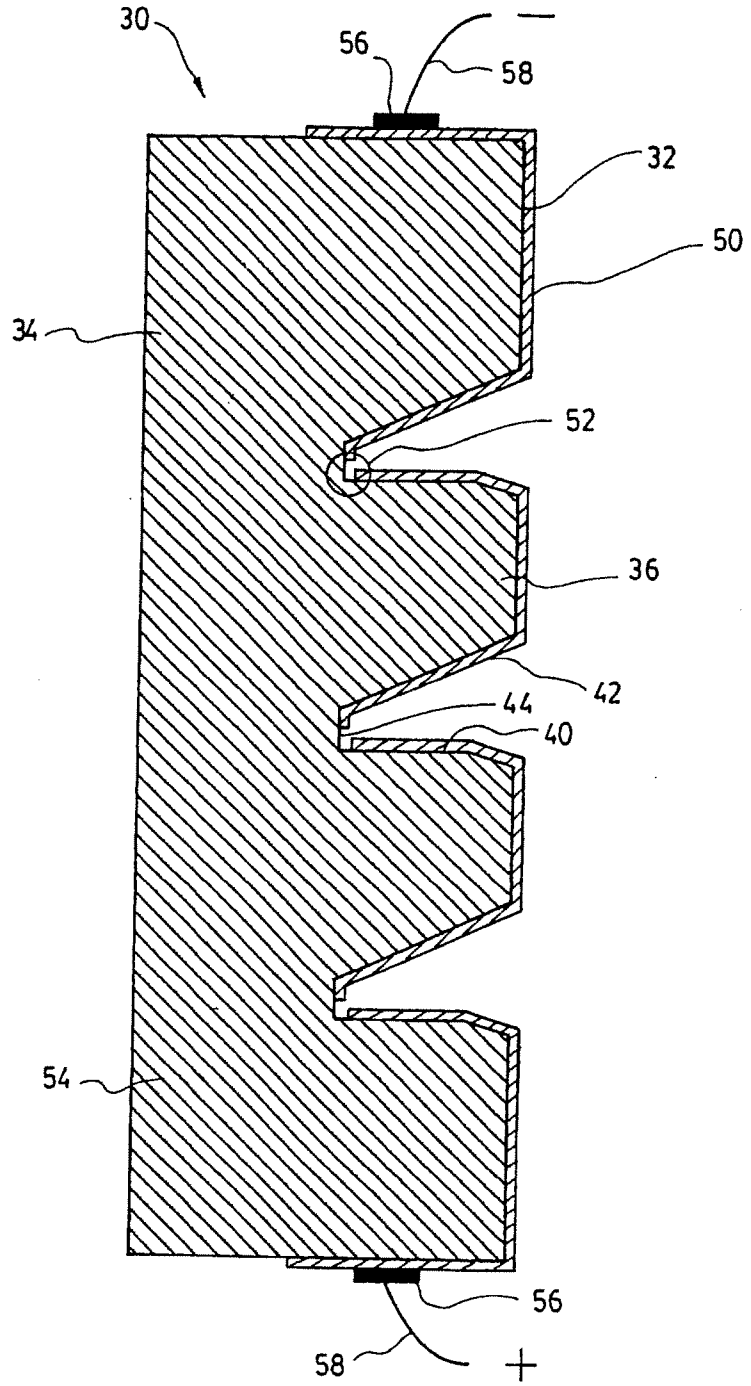

FIG. 2C

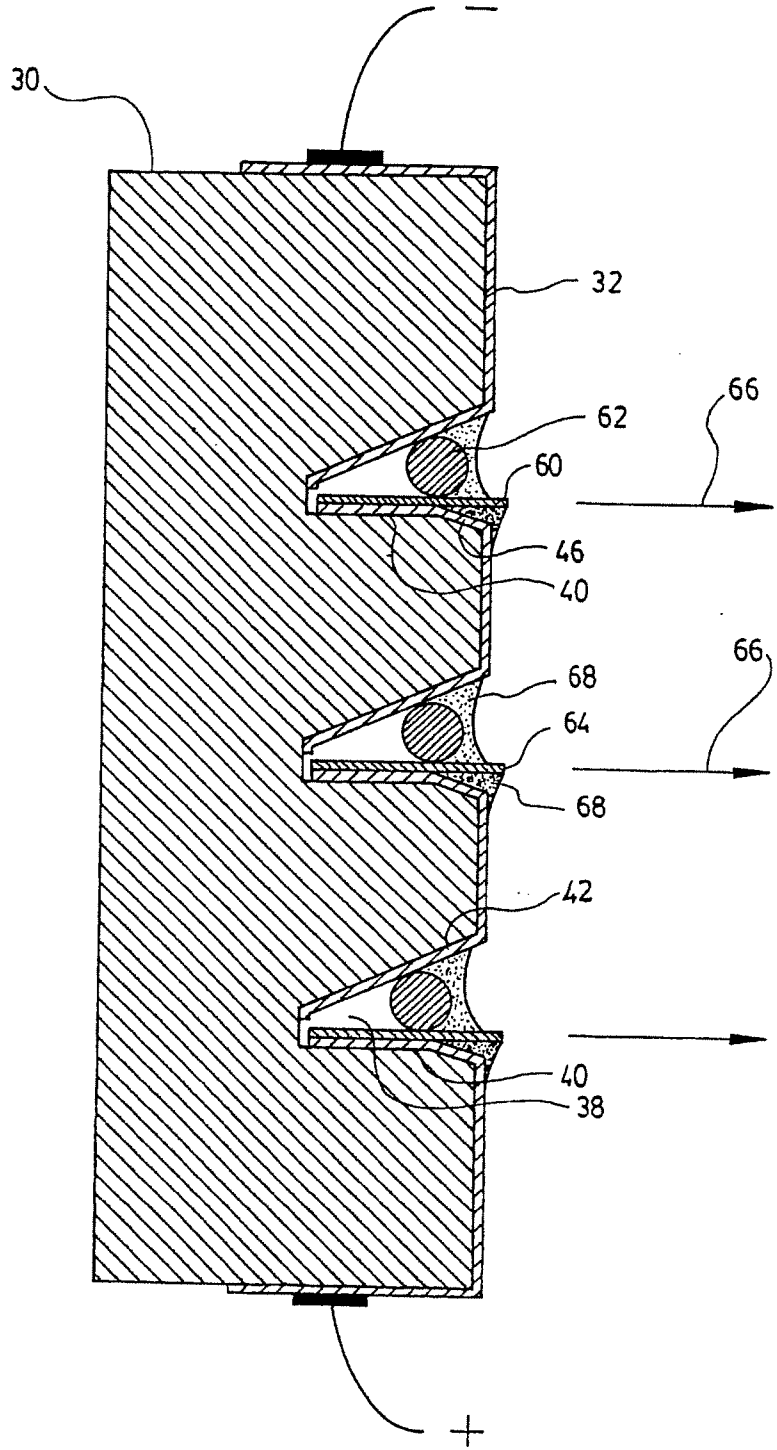

FIG. 2D

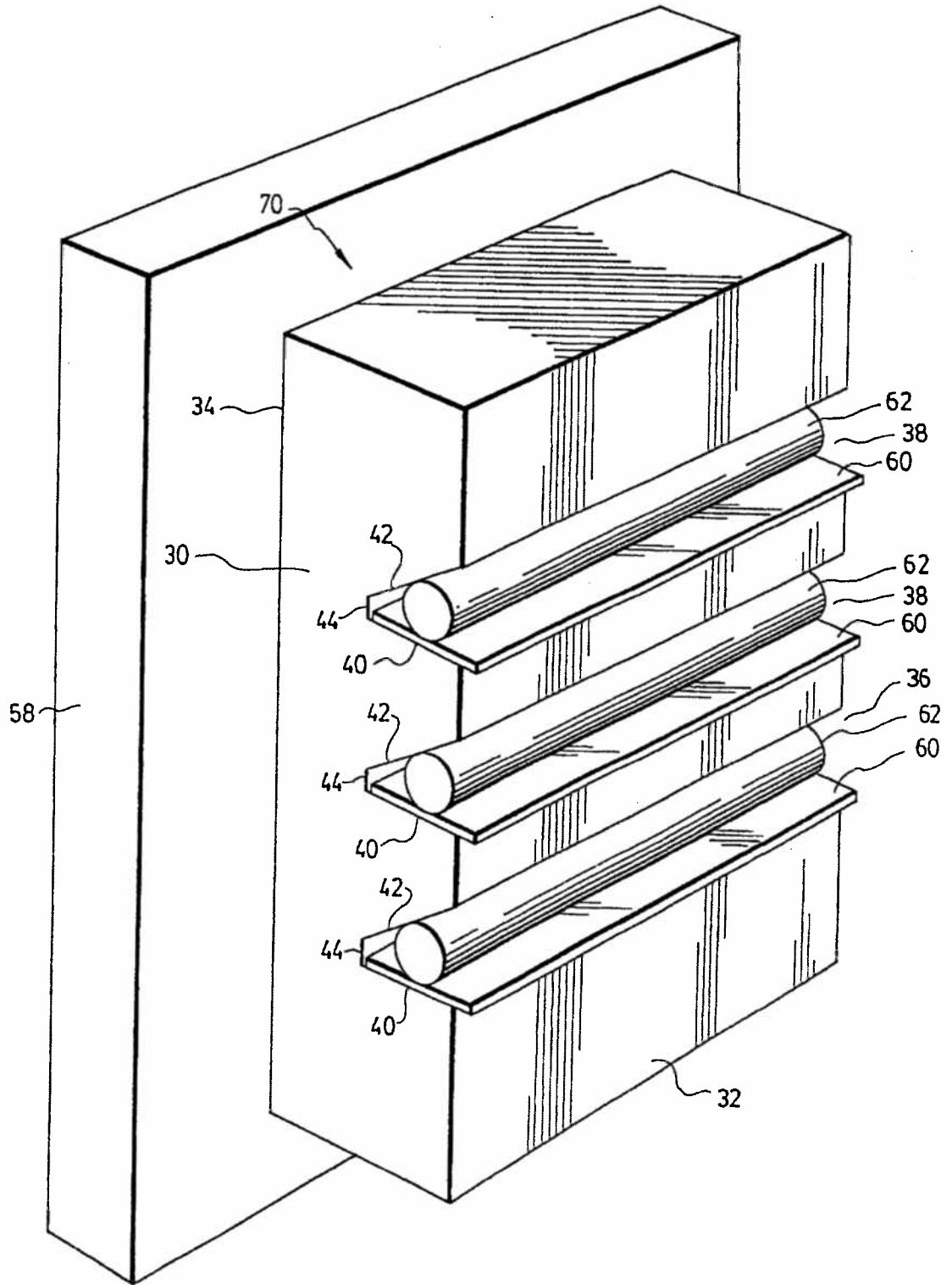

FIG. 3

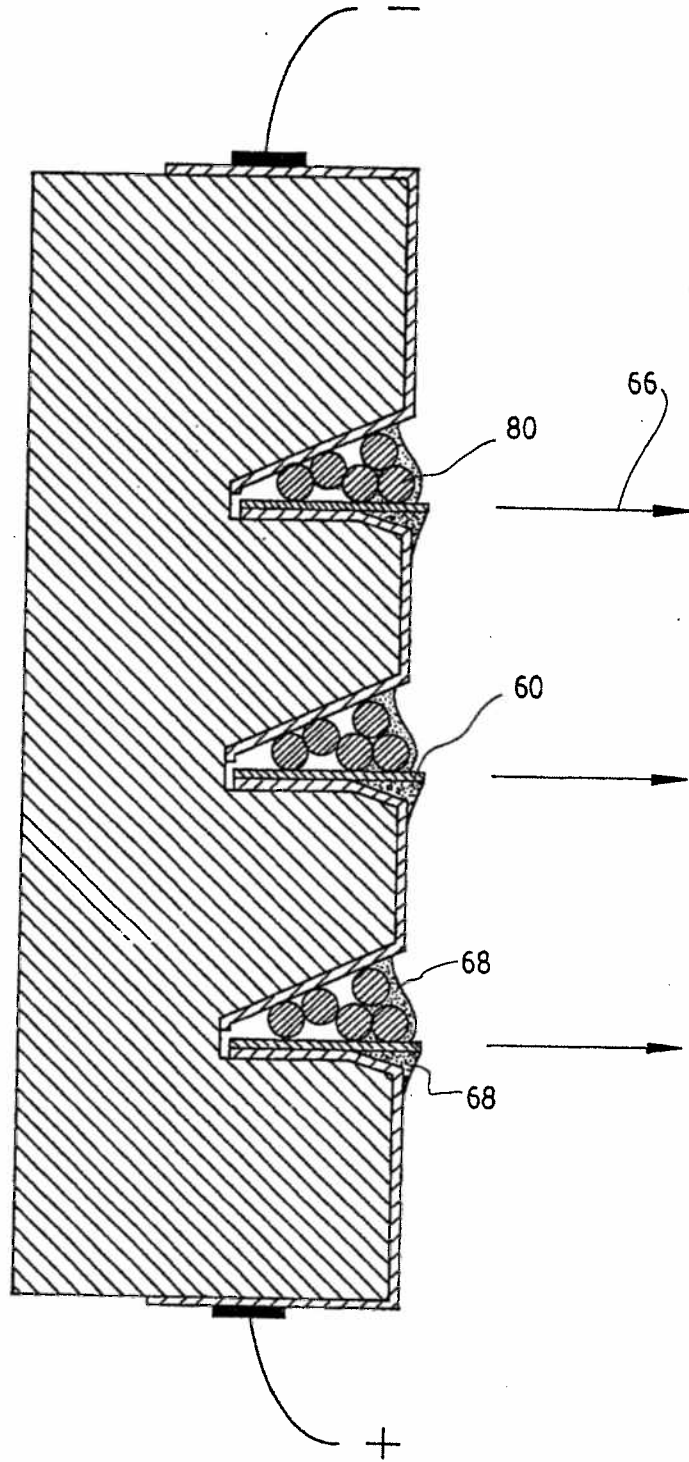

FIG. 4